

TECHNICAL BULLETIN

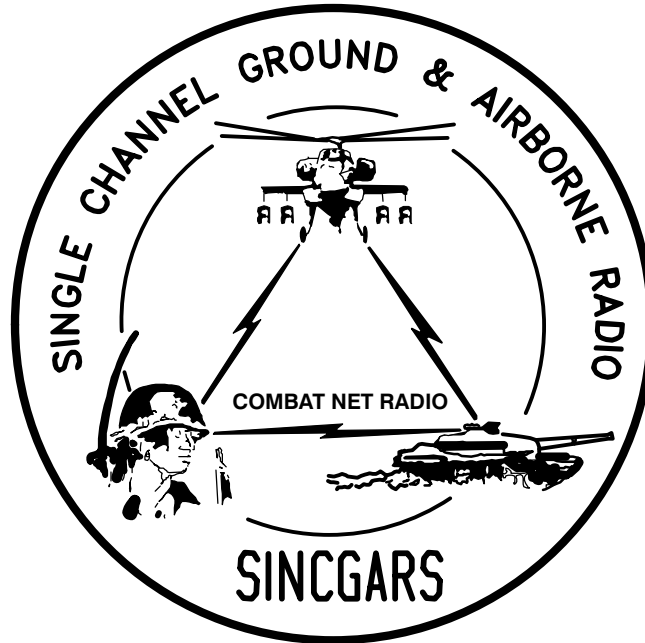

**INSTALLATION INSTRUCTIONS FOR
ELECTRONIC EQUIPMENT**

MK-2331/VRC (NSN 5895-01-292-6542) (EIC: N/A)

**TO PERMIT INSTALLATION OF
RADIO SET AN/VRC-89/91/92 SERIES
IN A**

**TRUCK, VAN, EXPANSIBLE, 5 TON, 6x6:
M934/M935**

Approved for public release; distribution is unlimited.

HEADQUARTERS, DEPARTMENT OF THE ARMY

1 SEPTEMBER 1999

**INSTALLATION INSTRUCTIONS FOR
 ELECTRONIC EQUIPMENT
 MK-2331/VRC (NSN 5895-01-292-6542) (EIC: N/A)
 TO PERMIT INSTALLATION OF
 RADIO SET AN/VRC-89/91/92 Series
 IN A
 TRUCK, VAN, EXPANSIBLE, 5 TON, 6x6:
 M934/M935**

REPORTING OF ERRORS AND RECOMMENDING IMPROVEMENTS

You can help improve this manual. If you find any mistakes, or if you know of a way to improve the procedures, please let us know. Mail your letter, DA Form 2028 (Recommended Changes to Publications and Blank Forms) or DA 2028-2 located in back of this manual direct to: Commander, US Army Communications-Electronics Command Fort Monmouth, ATTN: AMSEL-LC-LEO-D-CS-CFO, Fort Monmouth, New Jersey 07703-5000. The Fax number is 732-532-1413, DSN 992-1413. You may also e-mail your recommendation to AMSEL-LC-LEO-PUBS-CHG@ce-com3.monmouth.army.mil.

In either case a reply will be furnished direct to you.

TABLE OF CONTENTS

Subject	Section	Page
Scope	0.1	1
General Information	0.2	1
Maintenance Forms, Records, and Reports	0.3	1
Reports of Maintenance and Unsatisfactory Equipment	0.3.1	1
Report of Packaging and Handling Deficiencies	0.3.2	1
Discrepancy in Transportation Deficiency Report (TDR) (SF 361)	0.3.3	1
Consolidated Index of Army Publications	0.4	1
Purpose of Installation	1.	2
End Item or System to be Modified	2.	2
Application Times	3.	2
Time for Completion of Installation	3.1	2
Time for Installation of One Assembly or Component	3.2	2
Preparation for Installation	4.	2
Preparation of Vehicle	4.1	2
Preparation of MK	4.2	2
MK, Distribution, and Consumables	4.3	3
Tools and Test, Measurement, and Diagnostic Equipment (TMDE) Required	4.4	10
Installation Procedures	5.	11
Installation of Antenna AS-3900/VRC (antenna)	5.1	13
Installation of Antenna Base	5.1.1	13
Installation of Top Antenna Assembly	5.1.2	16
Installation of Electrical Equipment Shelf	5.2	17
Installation of Loudspeaker-Control Unit LS-671/VRC (speaker)	5.3	23
Installation of Mounting Base, Electrical Equipment MT-6352/VRC (mounting base)	5.4	24
Installation of Cables	5.5	26
Installation of Mounting Base, Electrical Equipment MT-6353/VRC	5.6	32
Post-Installation and Checkout	5.7	34
Appendix A. References		A1

*This manual supersedes TB 11-5820-890-20-33, dated 1 September 1993

LIST OF ILLUSTRATIONS

Figure	Title	Page
4-1(1)	MK Illustrated Parts List	6
4-1(2)	MK Illustrated Parts List	7
4-1(3)	MK Illustrated Parts List	8
4-2	Illustrated Parts List for Table 4-2	9
5-1(1)	MK and Radio Installation: MK Equipment Locations	11
5-1(2)	MK and Radio Installation: Radio Equipment Locations	12
5-2(1)	Antenna Base Installation: Installing Antenna Bracket	14
5-2(2)	Antenna Base Installation: Installing Antenna Base and OE-254 Adapter	15
5-3	Top Antenna Assembly Installation	16
5-4(1)	Electrical Equipment Shelf Installation: Typical Installation	18
5-4(2)	Electrical Equipment Shelf Installation: Alternate Installation A	20
5-4(3)	Electrical Equipment Shelf Installation: Alternate Installation B	21
5-4(4)	Electrical Equipment Shelf Installation: Alternate Installation C	22
5-4(5)	Electrical Equipment Shelf Installation: Alternate Installation D	22
5-5	Speaker Installation: Electrical Equipment Shelf	23
5-6	Mounting Base Installation	24
5-7(1)	Cable Installation: RF, Speaker and Power Cabling	27
5-7(2)	Cable Installation: Power Cabling	30
5-8	MT-6353/VRC Mounting Base Installation	32
5-9	Cable Diagram: For AN/VRC-89/91/92 Series	34

LIST OF TABLES

Number	Title	Page
4-1	Parts List for Installation of Radio Set AN/VRC-89/91/92 Series	4
4-2	Additional Items Required for Installation of Radio Set AN/VRC-92 Series	9

0.1 SCOPE.

This technical bulletin provides Installation Instructions for Electronic Equipment MK–2331/VRC, commonly referred to as the Mounting Kit (MK). The MK shall be installed into the following type of vehicle(s):

- Truck, Van, Expansive, 5 Ton, 6x6, M934
- Truck, Van, Expansive, 5 Ton, 6x6, M935

The MK is used for installation of radio set components at field locations. The information contained in this technical bulletin is the official authorization to perform the installation at the unit maintenance level.

NOTES

- This technical bulletin is not an authorization for requisition or turn-in of vehicles.
- This technical bulletin does not establish quantity or types of vehicles assigned to using units.

This technical bulletin does not contain information on the maintenance or replacement of the MKs. This information is contained in the MAC of TM 11–5820–890–20–2 and RPSTL of TM 11–5820–890–20P.

0.2 GENERAL INFORMATION.

The MK becomes operable when all the radio set components are installed in the vehicle and correct power is supplied. Refer to TM 11–5820–890–20–1 or TM 11–5820–890–20–2 for installation, Operational (OP) Check instructions, and required maintenance procedures. Refer to TM 11–5820–890–20P for repair parts.

Included in the Radio Set AN/VRC–89/91/92 Series is:

- Radio Set AN/VRC–89/91/92 Series (for RT–1523(C)/U)

0.3 MAINTENANCE FORMS, RECORDS, AND REPORTS.

0.3.1 Reports of Maintenance and Unsatisfactory Equipment. See section 4.2.2.3 for information.

0.3.2 Report of Packaging and Handling Deficiencies. See section 4.2.2.1 for information.

0.3.3 Discrepancy in Transportation Deficiency Report (TDR) (SF361). See section 4.2.2.2 for information.

0.4 CONSOLIDATED INDEX OF ARMY PUBLICATIONS.

Refer to the latest issue of DA Pam 25–30 to determine whether there are new changes, or additional publications pertaining to the equipment.

1. PURPOSE OF INSTALLATION.

The Electronic Equipment MK–2331/VRC (MK) contains the items needed to mount Radio Set AN/VRC–89/91/ 92 Series in a Truck, Van, Expansibles, 5 Ton, 6x6: M934/M935 (vehicle). If Radio Set AN/VRC–92 Series is authorized, see section 5.6 for instructions to install MT–6353/VRC mounting base.

2. END ITEM OR SYSTEM TO BE MODIFIED.

Not applicable.

3. APPLICATION TIMES.

3.1 Time for Completion of Installation. Using two people, a total of 4.0 work hours is required. Typical vehicle downtime is 4.5 hours.

3.2 Time for Installation of One Assembly or Component. The following table lists the time required to install one component. All times have been rounded off to the nearest half hour. The sum of these times will not reflect the typical vehicle downtime.

ITEM	SECTION	TIME
Antenna AS–3900/VRC	5.1	1.0
Mounting Base, Electrical Equipment MT–6352/VRC	5.4	1.5
Cables	5.5	1.0

4. PREPARATION FOR INSTALLATION.

This section explains how to prepare the vehicle and MK for installation.

4.1 Preparation of Vehicle. To prepare the vehicle for installation, insure that the site includes adequate lighting and a power source when drilling is required. Inspect the vehicle for damage that could affect installation. Have any such damage repaired before installing MK.

4.1.1 Items to be Removed. Remove existing AN/VRC–12 radio family installation kit/harness. See TM 11–5820–401–20–2 for removing items used with intercom systems, or TM 11–5820–401–20–1 (used without intercom systems), and TM 9–2320–280–20.

4.1.2 List of Items to be Retained. Not applicable.

4.2 Preparation of MK. To prepare MK, unpack, inspect and check inventory.

4.2.1 Precautions During Handling. Observe these steps to prevent equipment damage.

- a. Keep dust covers in place on connectors.
- b. Do not disassemble or modify parts in MK unless authorized to do so.
- c. Keep mounting hardware covered and protected until needed.
- d. When exposed to moisture, rain or salt water, keep all parts dry to prevent corrosion.

4.2.2 Unpack and Inspect Equipment.

4.2.2.1 Inspect Packaging for Evidence of Damage. Any shipping damage should be reported on SF364 Report of Discrepancy (ROD) as prescribed in AR 735–11–2/DLAR 4140.55/NAVMATINST 4355.73A/AFR 400–64/MCO 4430.3F.

4.2.2.2 Unpack and Inventory MK. If any item is missing, fill out and forward Transportation Deficiency Report (TDR) (SF361) as described in AR 55–38/NAVSUPINST 4610.33C/AFR 75–18/MCO P4610.19D/DLAR 4500.15.

4.2.2.3 Examine Each Item for Damage. If any item is damaged, fill out and forward SF364 Report of Discrepancy (ROD) as prescribed in AR 735–11–2/DLAR 4140.55/NAVMATINST 4355.73A/AFR 400–64/MCO 4430.3F. All damages should be reported as prescribed by DA Pam 738–750, as contained in Maintenance Management Update.

4.3 MK, Distribution, and Consumables.

4.3.1 Items Supplied in MK and/or Required for Installation. Use Table 4–1 and figure 4–1 to identify and inventory MK parts supplied to install Radio Set AN/VRC–89/91/92 Series. Refer to Table 4–2 and figure 4–2 to identify additional items required to install Radio Set AN/VRC–92 Series.

4.3.2 Distribution and Issue Instructions.

- a. US Forces: Do not requisition MK. They will be shipped automatically.
- b. US Army Depots: Requisition MK through supply channels.
- c. Multiservice: Instructions shall be included for multiservice modifications.
- d. MAP/MAS Countries: Instructions shall be provided for MAP/MAS countries.

Table 4-1. Parts List for Installation of Radio Set AN/VRC-89/91/92 Series

NSN	ITEM DESCRIPTION AND PART NUMBER	QUANTITY IN MK	SMR CODE	FIGURE, ITEM NO.
5985-01-297-2971	Antenna AS-3900/VRC (A3017899-1)	2	PAOOF A	4-1, 2
5305-00-847-1159	Screw, Cap, Hexagon (3/8-16 x 1 3/4 in) MS35307-365	8	PAOZZA	
5310-00-913-8881	Nut, Hexagon (3/8-16 in) MS51971-3	8	PAOZZA	
5310-00-061-1258	Washer, Lock, Internal/External-Toothed (3/8 in) MS45904-76	16	PAOZZA	
5310-00-889-2527	Washer, Lock, Internal/External-Toothed (5/16 in) MS45904-72	4	PAOZZA	
5306-00-225-9086	Bolt, Machine (5/16-24 x 5/8 in) MS90726-31 (Not Used)	2	PAOZZA	
5330-01-205-2864	Gasket (A3013655-1)	2	PAOZZA	
5965-01-222-1420	Loudspeaker - Control Unit LS-671/VRC (A3014065-1)	2	PAOFFA	4-1, 5
5975-01-188-8873	Mounting Base, Electrical Equipment MT-6352/VRC (A3013367-1)	1	PAOOF A	4-1, 1
5306-00-225-9089	Bolt, Machine (5/16-24 x 1 in) MS90726-34	5	PAOZZA	
5310-00-889-2527	Washer, Lock, Internal/External-Toothed (5/16 in) MS45904-72 (5 Not Used)	10	PAOZZA	
5310-00-880-7746	Nut, Hexagon (5/16 - 24 in) MS51968-5 (Not Used)	5	PAOZZA	
5305-00-847-1159	Screw, Cap, Hexagon (3/8-16 x 1 3/4 in) MS35307-365	8		
5995-01-259-9245	Cable Assembly, Power, Electrical CX-13302/VRC (20 FT, 0 IN) (A3014039-6)	1	PAOZZA	4-1,14
5995-01-219-7035	Cable Assembly, Radio Frequency CG-3855/VRC (18 FT, 0 IN) (A3014031-8)	2	PAOZZA	4-1,16
5995-01-219-4704	Cable Assembly, Special Purpose, Electrical CX-13292/VRC (6 FT, 0 IN) (A3014038-3)	2	PAOZZA	4-1,15
5985-01-306-3828	Adapter, Antenna - OE-254 (A3018320-1)	2	PAOZZA	4-1, 6
5306-00-225-9089	Bolt, Machine (5/16-24 x 1 in) MS90726-34	12	PAOZZA	
5306-00-225-9089	Bolt, Machine (5/16-24 x 1 in) MS90726-34	12	PAOZZA	
	Bracket, Mounting - Antenna (A3050655-1)	2	XBOZZA	4-1, 7
	Bracket, Mounting - Reinforcement (A3014121-1)	2	XBOZZA	4-1, 9
	Bracket, Multiple Angle (A3014541-1)	2	XBOZZA	4-1, 8
	Bracket, Multiple Angle (A3014540-1)	2	XBOZZA	4-1,12
	Channel, Structural (A3014123-1)	4	XBOZZA	4-1,10
5340-00-809-1490	Clamp, Loop (1/4-1/4 in) MS21333-98	12	PAOZZA	
5340-00-088-1254	Clamp, Loop (5/8-1/4 in) MS21333-104	4	PAOZZA	
5340-00-809-1494	Clamp, Loop (3/4-1/4 in) MS21333-105	8	PAOZZA	
4020-01-341-8795	Fiber Rope Assembly, Single Leg (A3167672-1)	2	PAOZZA	4-1, 4

Table 4-1. Parts List for Installation of Radio Set AN/VRC-89/91/92 Series Continued

NSN	ITEM DESCRIPTION AND PART NUMBER	QUANTITY IN MK	SMR CODE	FIGURE, ITEM NO.
5325-00-783-4754	Grommet, Nonmetallic MS21266-5N	1	PAOZZA	
	Grommet, Nonmetallic (A3046173)	2	XBOZZA	
5325-00-682-1854	Grommet, Nonmetallic (1/4 in) MS35489-65	2	PAOZZA	
5325-00-174-5315	Grommet, Nonmetallic (1/4 in) MS35489-7	2	PAOZZA	
5325-00-174-9332	Grommet, Nonmetallic (11/16 in) MS35489-48	1	PAOZZA	
	Grommet, Retainer (A3140057-1)	2	XBOZZA	
5965-00-043-3463	Handset H-250/U	2	PAOZZA	4-1, 3
5310-00-880-7746	Nut, Hexagon (5/16-24 in) MS51968-5	4	PAOZZA	
	Nut, Plain, Plate (A3014122-1)	6	XBOZZA	4-1,11
5305-00-068-0502	Screw, Cap, Hexagon (1/4-20 x 3/4 in) MS90725-6	4	PAOZZA	
5305-00-432-4253	Screw, Tapping, Thread Forming, Pan-Head (1/4-14 x 3/4 in) MS51861-67	16	PAOZZA	
5305-00-432-4251	Screw, Tapping, Thread Forming, Pan-Head (1/4-14 x 1/2 in) MS51861-65	4	PAOZZA	
5305-01-313-3976	Screw, Tapping, Thread Forming, Hex-Head (5/16-12 x 1 in) MS51850-108	14	PAOZZA	
5975-00-111-3208	Shelf, Electrical Equipment (A3014542-1)	1	PAOZZA	4-1,13
	Strap, Tiedown, Electrical Components MS3367-5-9	10	PAOZZA	
5310-00-081-4219	Washer, Flat (5/16 in) MS27183-12	14	PAOZZA	
5310-00-582-5965	Washer, Lock (1/4 in) MS35338-44	24	PAOZZA	
5310-00-407-9566	Washer, Lock (5/16 in) MS35338-45	14	PAOZZA	
5310-00-889-2527	Washer, Lock, Internal/External-Toothed (5/16 in) MS45904-72	10	PAOZZA	

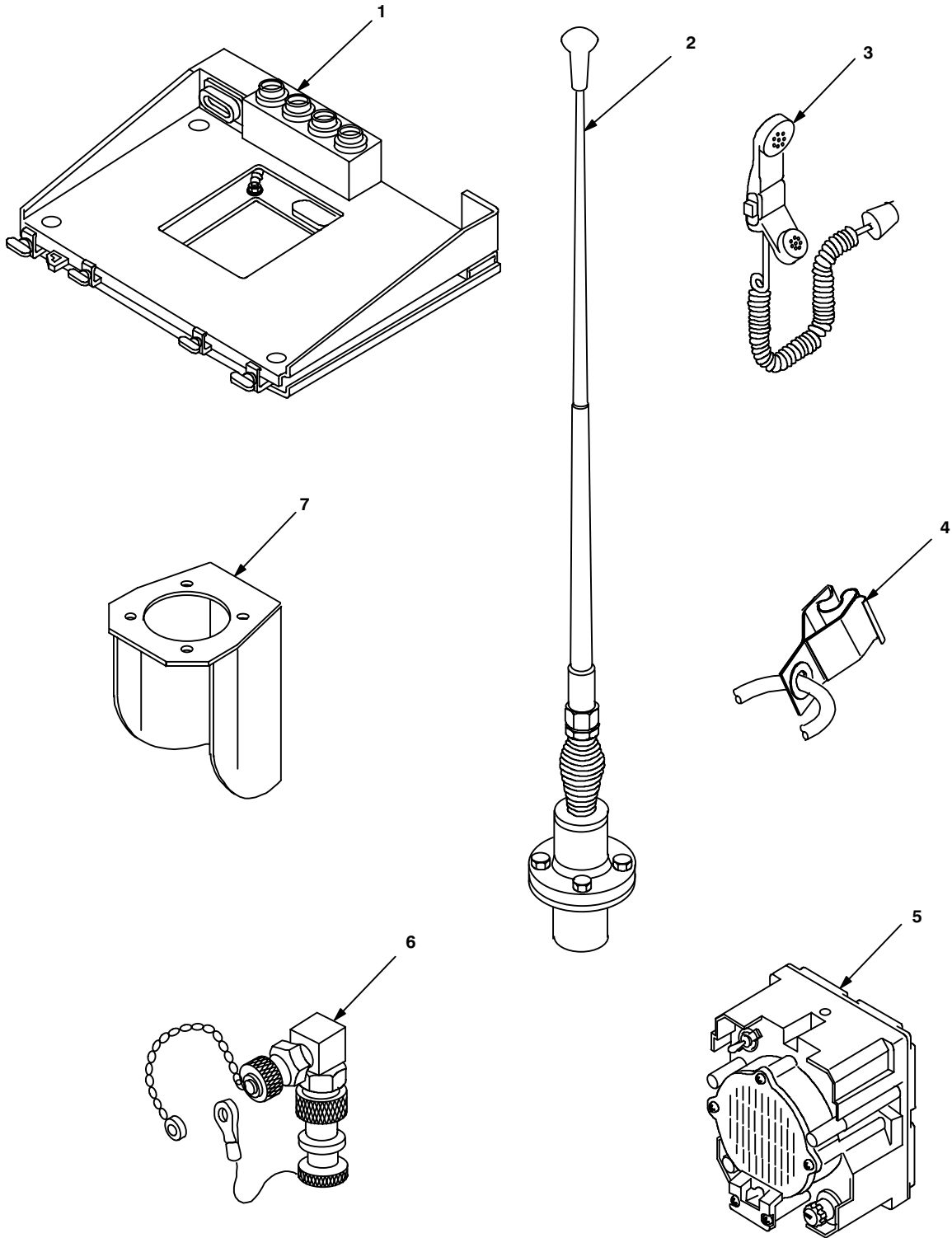

Figure 4-1 (1). MK Illustrated Parts List

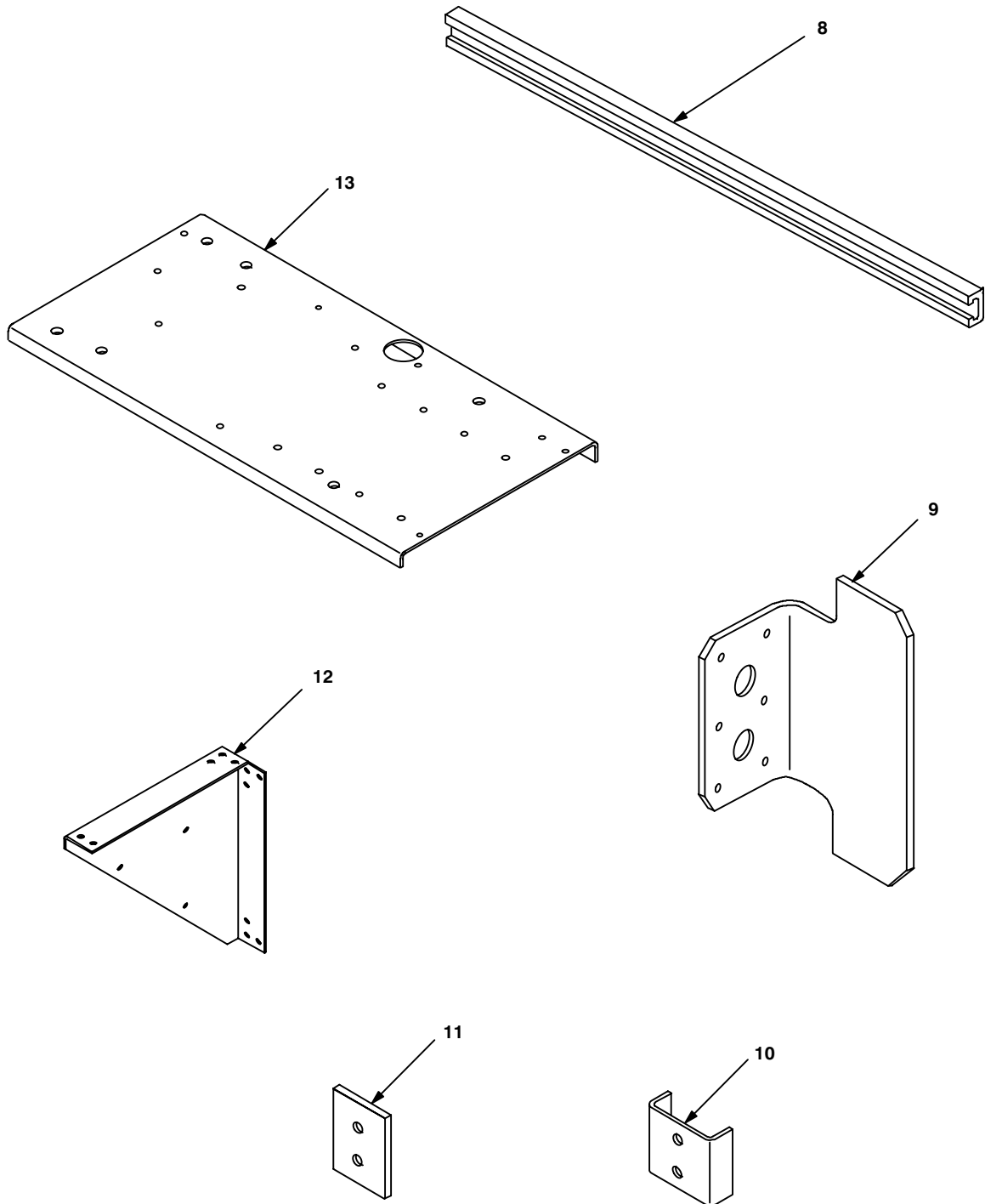

Figure 4-1 (2). MK Illustrated Parts List

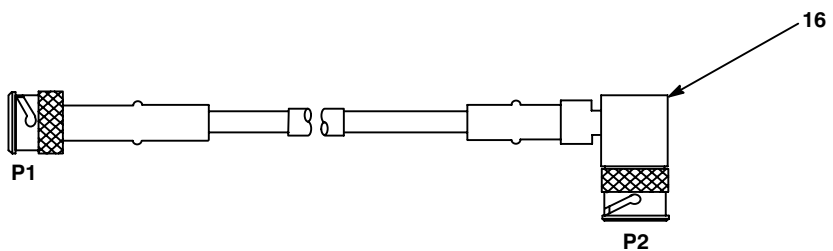
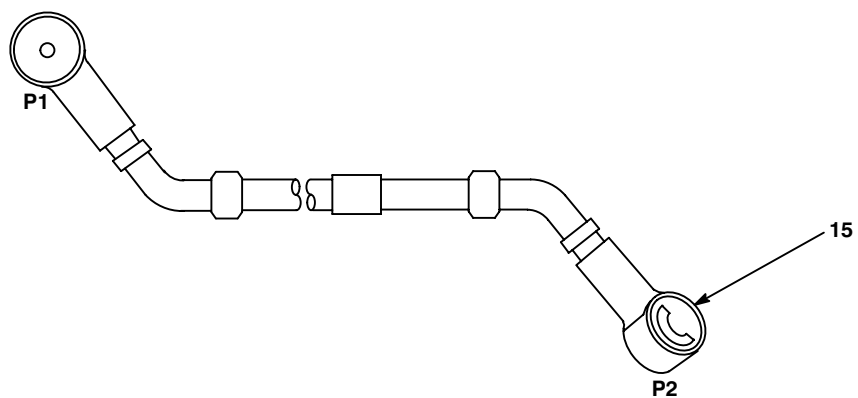
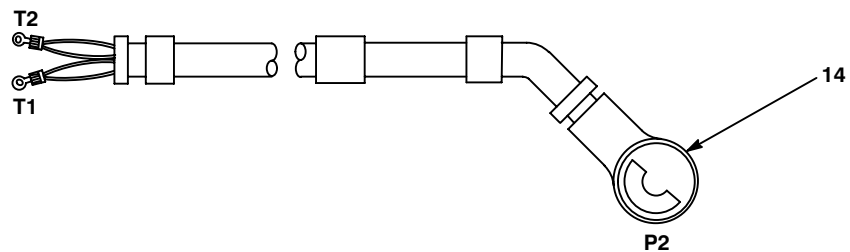

Figure 4-1 (3). MK Illustrated Parts List

Table 4-2. Additional Items Required for Installation of Radio Set AN/VRC-92 Series

NSN	ITEM DESCRIPTION AND PART NUMBER	QUANTITY IN MK	SMR CODE	FIGURE, ITEM NO.
5975-01-235-1962	Mounting Base, Electrical Equipment MT-6353/VRC (A3014053-1)	1	PAOOHA	4-2, 1
5306-00-225-9089	Bolt, Machine (5/16-24 x 1 in) MS90726-34	4	PAOZZA	
5310-00-880-7746	Nut, Hexagon (5/16-24 in) MS51968-5 (Not Used)	2	PAOZZA	
5310-00-889-2527	Washer, Lock, Internal/External-Toothed (5/16 in) MS45904-72 (2 Not Used)	6	PAOZZA	
5310-00-081-4219	Washer, Flat (5/16 in) MS27183-12	2	PAOZZA	
5975-00-111-3208	Nut Strip (A3014064-1) (Not Used)	1	XBOZZA	4-2, 5
5975-00-111-3208	Strap, Tiedown, Electrical Components MS3367-5-9	4	PAOZZA	
5995-01-300-9324	Cable Assembly, Power, Electrical CX-13303/VRC (4 FT, 6 IN) (A3014040-9)	1	PAOZZA	4-2, 4
5995-01-222-4209	Cable Assembly, Special Purpose, Electrical CX-13291/VRC (3 FT, 0 IN) (A3014037-1)	1	PAOZZA	4-2, 2
5995-01-219-7025	Cable Assembly, Radio Frequency CG-3856/VRC (5 FT, 0 IN) (A3014032-3)	1	PAOZZA	4-2, 3

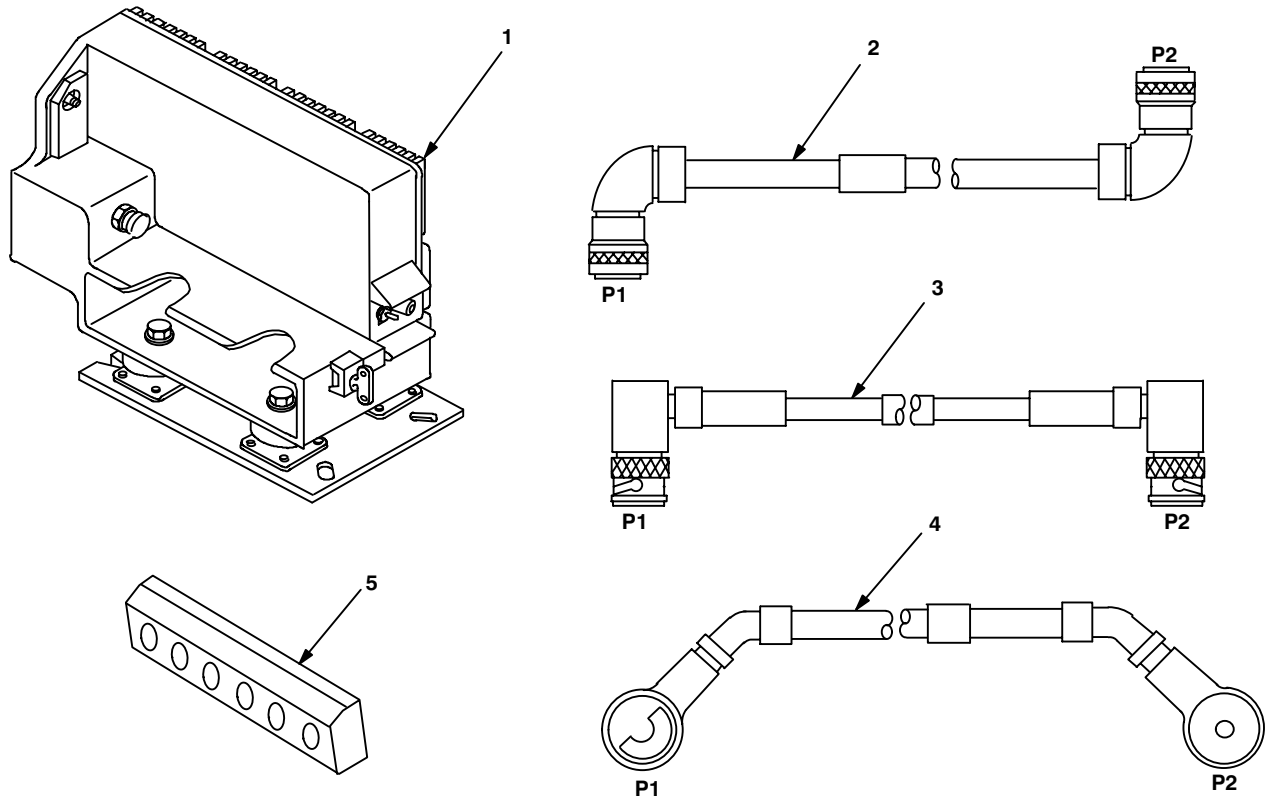

Figure 4-2. Illustrated Parts List for Table 4-2

4.3.3 Consumable Materials. The table below lists materials required for installation but not supplied with MK.

NSN	NOMENCLATURE
8040-00-117-8510	Adhesive-Sealant, Clear, RTV
6850-00-880-7616	Silicone Compound, MIL-S-8660
8030-00-292-1102	Conductive Anti-seize Compound

4.4 Tools and Test, Measurement, and Diagnostic Equipment (TMDE) Required. The following tools and TMDE are needed for installation.

NOMENCLATURE	NSN	QUANTITY
Radio Set*		1
Electric Grinder or Equivalent		1
Pocket Knife, Electrician's	5110-00-240-5943	1
Screwdriver, No. 2 Point Phillips, 4 in	5120-00-234-8913	1
Screwdriver, 1/4 in Flatblade, 4 in	5120-00-222-8852	1
Pliers, Round Nose	5120-00-240-6172	1
Pliers, Diagonal Cutting	5110-00-965-0974	1
Frame, Hand Hacksaw	5110-00-289-9657	1
Blade	5110-00-277-4589	1
Wrench, Open/Box: 7/16 in	5120-00-228-9505	1
1/2 in	5120-00-228-9506	1
9/16 in	5120-00-228-9507	1
5/16 in	5120-00-228-9503	1
3/4 in	5120-00-228-9510	1
Handle, Socket Wrench	5120-00-240-5364	1
Socket: 7/16 in	5120-00-227-6703	1
1/2 in	5120-00-237-0977	1
9/16 in	5120-00-227-6704	1
5/16 in	5120-00-235-5878	1
3/4 in	5120-00-227-6705	1
Electric Drill	5130-00-889-8994	1
Drill Bit: 3/16 in	5133-00-243-9612	1
1/4 in	5133-00-227-9658	1
11/32 in	5133-00-227-9664	1
1 1/4 in		1
5/16 in	5133-00-227-9662	1
3/4		1

5. INSTALLATION PROCEDURES.

This section describes where and how to install MK items in the vehicle. See figure 5-1 for an overall view of where the MK equipment, as well as radio components, will typically be installed. When installing MK equipment, be sure to read and follow instructions and illustrations carefully. If Radio Set AN/VRC-92 Series is authorized, see section 5.6 for instructions to install MT-6353/VRC mounting base.

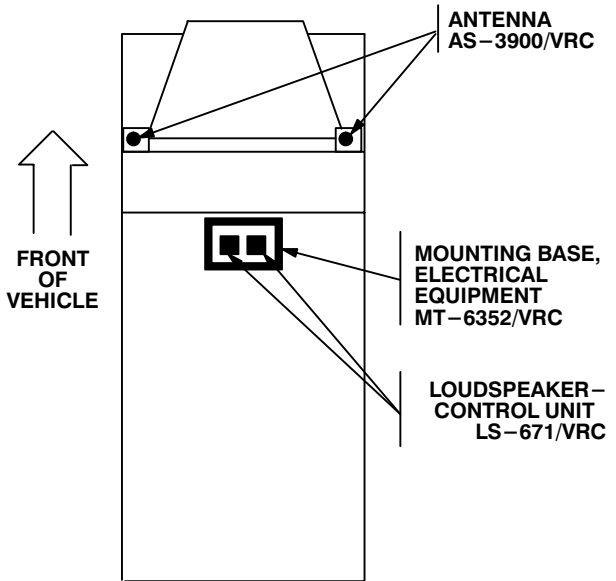
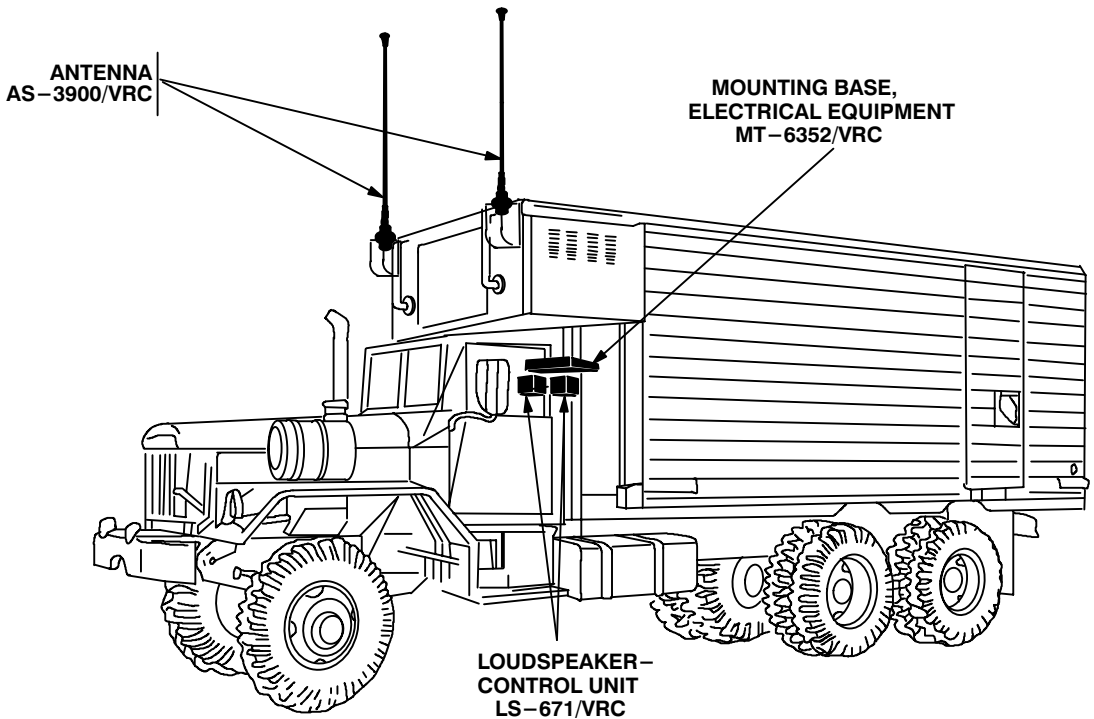

TOP VIEW

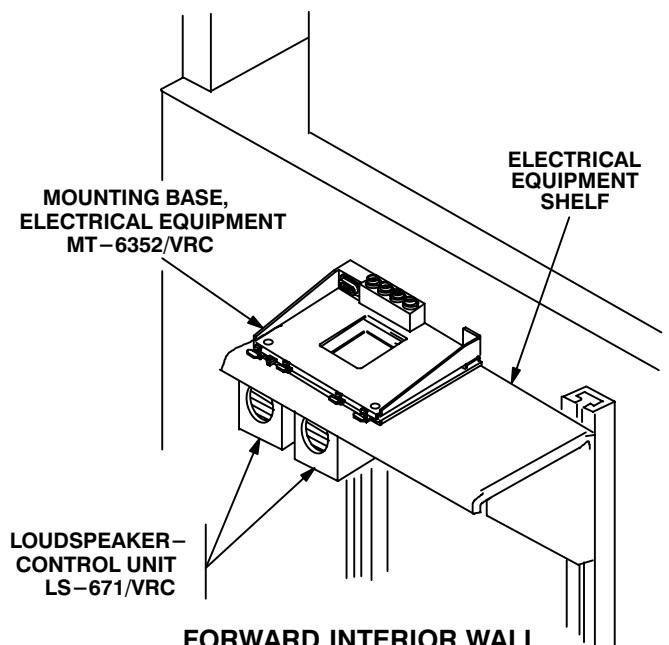

FORWARD INTERIOR WALL

Figure 5-1 (1). MK and Radio Installation: MK Equipment Locations

5. INSTALLATION PROCEDURES. Continued.

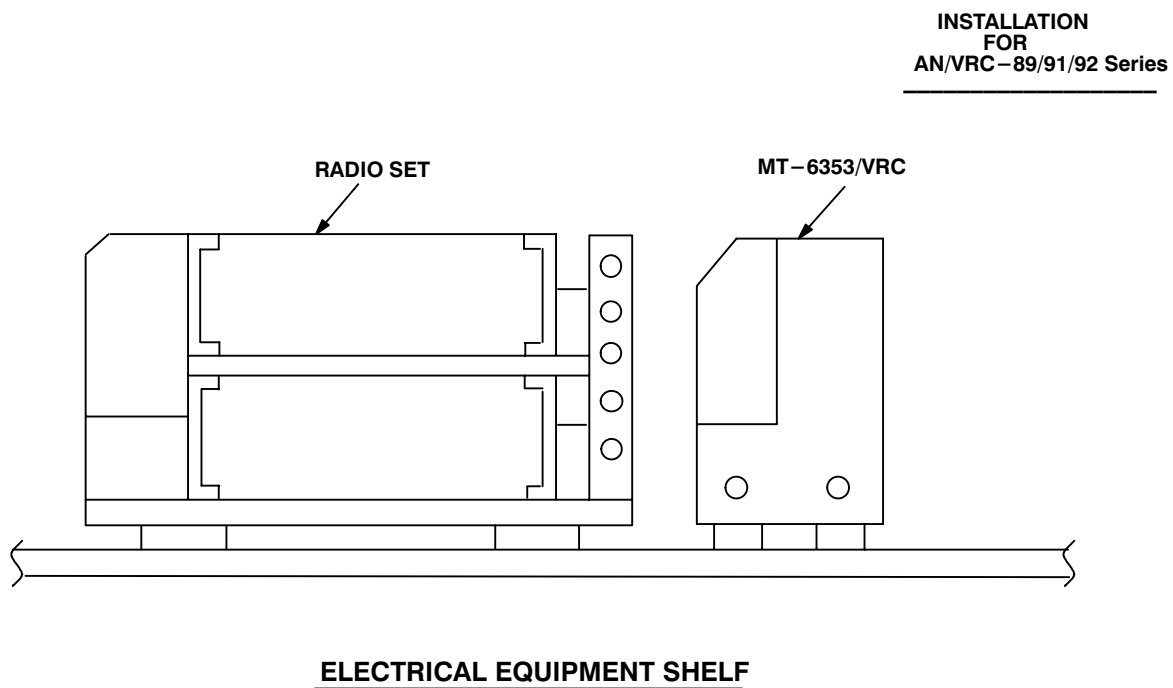

Figure 5-1 (2). MK and Radio Installation: Radio Equipment Locations

5.1 Installation of Antenna AS-3900/VRC (antenna).

5.1.1 Installation of Antenna Base. Use the following procedures to install both antenna bases. See Figure 5-1(1) for locations.

ITEM	ACTION	REMARKS
NOTE		
Apply a thin coat of adhesive-sealant to both sides of each internal/external-toothed (IET) washer during installation, and to the area of contact where IET washer is to be placed.		
a. Holes for reinforcement bracket (1) and antenna bracket (2).	Using dimensions shown and antenna bracket as a template, drill six 1/4 in diameter holes (through outer panel) and a 3/4 in diameter hole (through outer and inner panels). See figure 5-2 (1). Remove a 1" diameter area of paint around the exterior and interior surfaces of the six drilled holes. Clean the paint removed areas and apply a thin coat of conductive anti-seize compound.	Tools: Electric drill, 1/4 in drill bit and 3/4 in drill bit.
b. Reinforcement bracket (1).	Remove a 1" diameter area of paint around all six mounting holes on both sides of the reinforcement bracket (1). Clean the paint removed areas and apply a thin coat of conductive anti-seize compound.	Tools: Electric drill or equivalent.
c. Antenna bracket (2).	Enlarge six existing mounting holes to 11/32 in diameter. Remove a 1" diameter area of paint around all six mounting holes on both side of the antenna bracket (2). Clean the paint removed areas and apply a thin coat of conductive anti-seize compound.	Tools: Electric drill 11/32 in drill bit and electric grinder or equivalent.
d. Reinforcement bracket (1), antenna bracket (2), five hex-head tapping screws (3) and five internal/external-toothed (IET) washers (4).	With exhaust shield of reinforcement bracket facing exhaust pipe, install and secure to holes drilled in step a (except bottom right hole).	Tools: 1/2 in socket.

5.1.1 Installation of Antenna Base. Continued

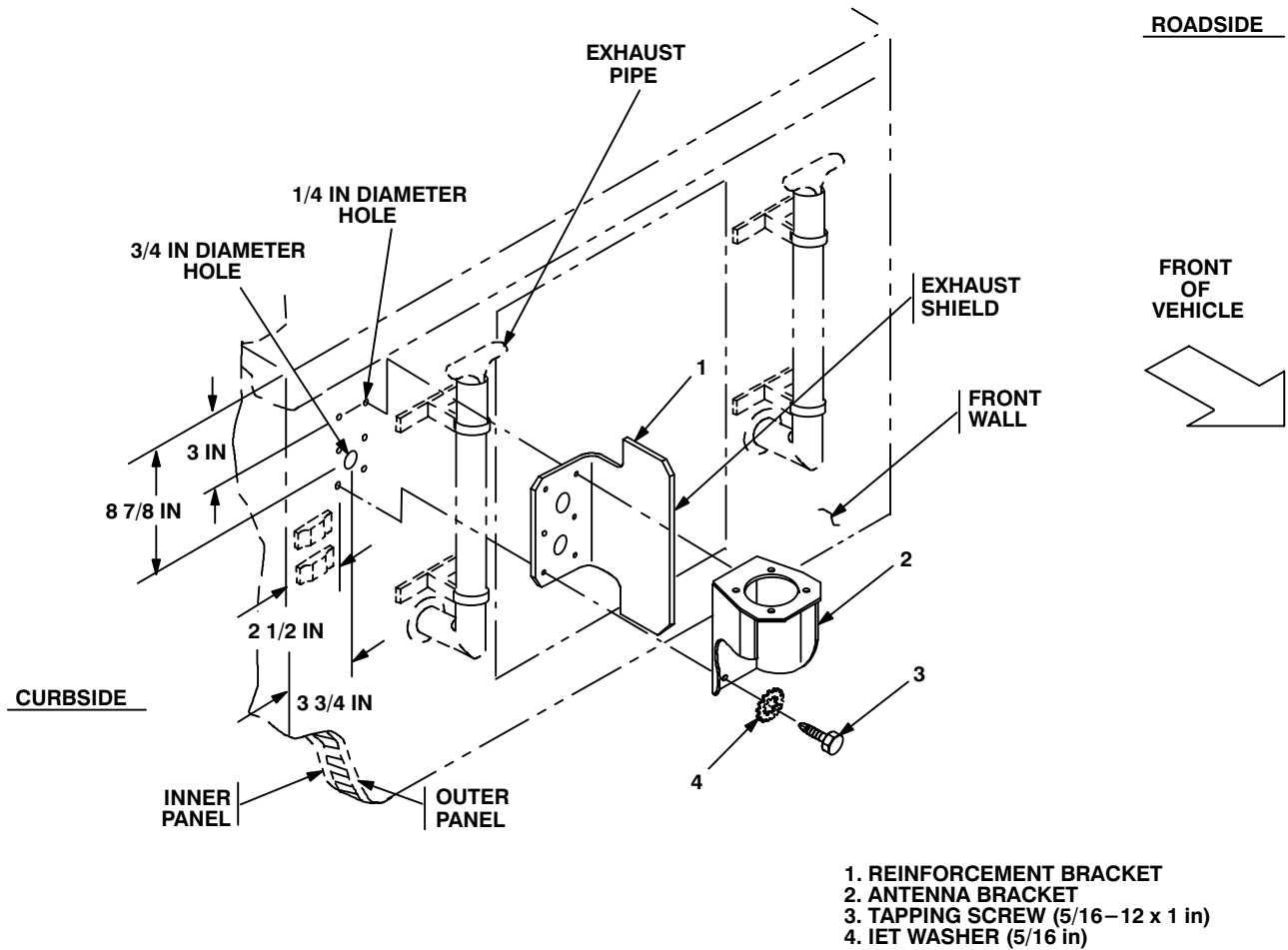

Figure 5-2 (1). Antenna Base Installation: Installing Antenna Bracket

5.1.1 Installation of Antenna Base. Continued

ITEM	ACTION	REMARKS
e. Gasket (4).	Place on antenna bracket (5) and align with mounting holes. See figure 5-2 (2).	
f. Antenna base (1).	Place on top of gasket (4) and antenna bracket (5). Align mounting holes.	
g. Four cap screws (2), eight IET washers (3) and four nuts (7).	Install and secure to antenna base (1) and antenna bracket (5).	Tools: 9/16 in socket and 9/16 in wrench.
h. Ground strap (10), two IET washers (8) and hex-head tapping screw (9).	Install and secure to right bottom hole in antenna bracket (5), reinforcement bracket (6) and front wall.	Tools: 1/2 in socket.
i. OE-254 antenna adapter (14), nut (13), two electrical covers (12), pan-head machine screw (11), lock washer (15) and nut (16).	Install and secure to mounting holes in antenna bracket (5). See figure 5-2 (2), detail A.	Tools: 3/4 in wrench, 5/16 in wrench and Phillips screwdriver.

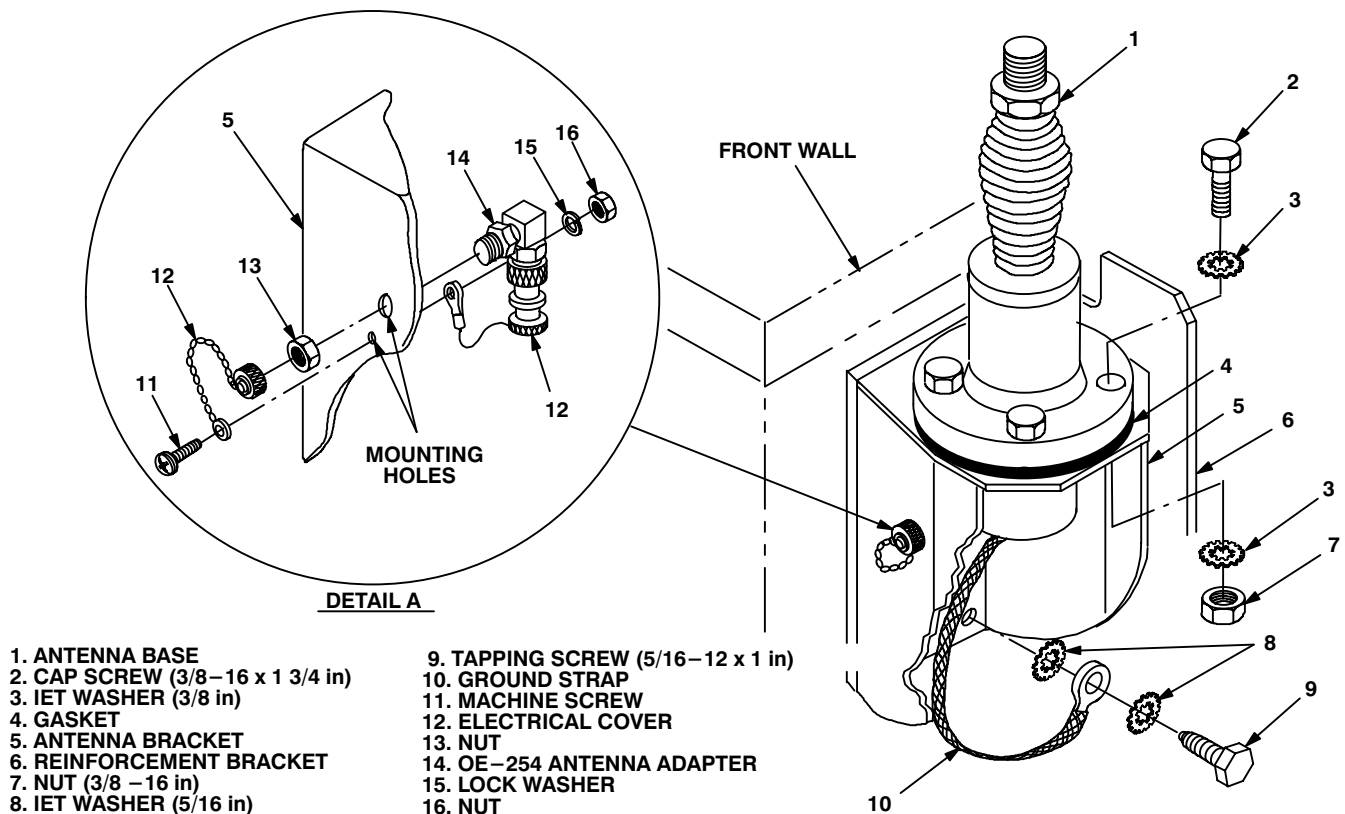
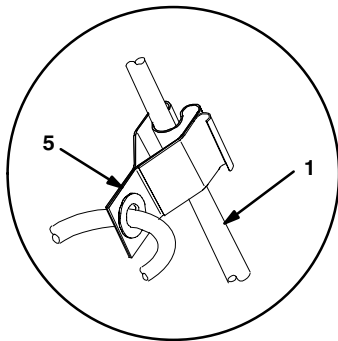

Figure 5-2 (2). Antenna Base Installation: Installing Antenna Base and OE-254 Adapter

5.1.2 Installation of Top Antenna Assembly. The top portion of the antenna includes a lower element and an upper element (with installed cap). Use the following procedure to assemble, install and tie down all antennas.

ITEM	ACTION	REMARKS
a. Antenna elements (1, 2).	Apply silicone compound to element threads and assemble. See figure 5-3.	
b. Antenna element (2).	Install and hand-tighten to antenna base (3).	
c. Lock wire (4).	Install to antenna element (2) and antenna base (3). See figure 5-3, detail A.	
	Cut and remove excess wire with diagonal cutting pliers.	
d. Fiber rope assembly (5).	Attach clip to antenna element (1). Tie rope to vehicle to position antenna in desired location. See figure 5-3, detail B.	



DETAIL B

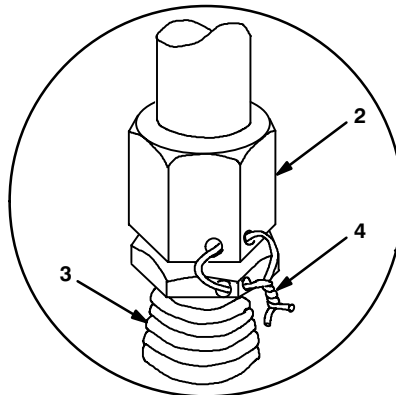

DETAIL A

- 1. ANTENNA ELEMENT (UPPER)
- 2. ANTENNA ELEMENT (LOWER)
- 3. ANTENNA BASE
- 4. LOCK WIRE
- 5. FIBER ROPE ASSEMBLY

Figure 5-3. Top Antenna Assembly Installation

5.2 Installation of Electrical Equipment Shelf. Use steps a through p for typical installation of shelf. Alternate installations are also included in this section. If an alternate installation is used, drilling dimensions and shelf assembly may be determined by vehicle commander.

ITEM	ACTION	REMARKS
a. Duct cover.	Remove and reinstall upside down from original position (duct cover lever to the right). See Figure 5–4 (1).	
b. Two angle brackets (4).	Measure 48 in from bottom (two-hole end) and cut to length.	Tools: Hacksaw
c. Existing mounting hardware.	Remove from four existing holes in forward wall. See Figure 5–4 (1) for location(s).	Insure holes are 31 in apart for angle bracket (4).
d. Two holes through each angle bracket (4).	Placing each angle bracket (4) against forward wall (two hole end on floor), mark hole placement by aligning with existing holes; then drill four 5/16 in diameter holes. See Figure 5–4(1), detail A. Remove a 1" diameter of paint around both sides of two holes drilled in each angle bracket (4). Clean the paint removed areas and apply a thin coat of conductive anti–seize compound.	Tools: Electric drill, 5/16 in drill bit and electric grinder or equivalent.
e. One of two existing holes through plate nuts (3).	Enlarge to 11/32 in diameter. See Figure 5–4(1). Remove a 1" diameter of paint around both sides of mounting holes in plate nuts (3). Clean the paint removed areas and apply a thin coat of conductive anti–seize compound.	Tools: Electric drill, 11/32 in drill bit and electric grinder or equivalent.
f. Four plate nuts (1).	Place angle brackets (4) on floor; then insert two in each.	
g. Two angle brackets (8) and four structural channels (2).	Remove a 1" diameter of paint around all holes on both sides of four structural channels (2). Remove a 1" diameter of paint around two holes on both sides of two angle brackets (8) that mate with structural channels (2). Clean the paint removed areas and apply a thin coat of conductive anti–seize compound.	Tools: Electric grinder or equivalent.
h. Two angle brackets (8), four structural channels (2), eight machine bolts (11), eight lock washer (10) and eight flat washers (9).	Install (without securing) to two angle brackets (4) and four plate nuts (1).	Tools: 1/2 in socket.
i. Two angle brackets (4).	Raise complete assembly; then align holes holes drilled in step d with four existing mounting holes in forward wall. See Figure 5–4 (1) for location(s).	
j. Existing mounting hardware removed in step c.	Install (without securing) to two angle brackets (4) and existing mounting holes in forward wall.	

5.2 Installation of Electrical Equipment Shelf. Continued

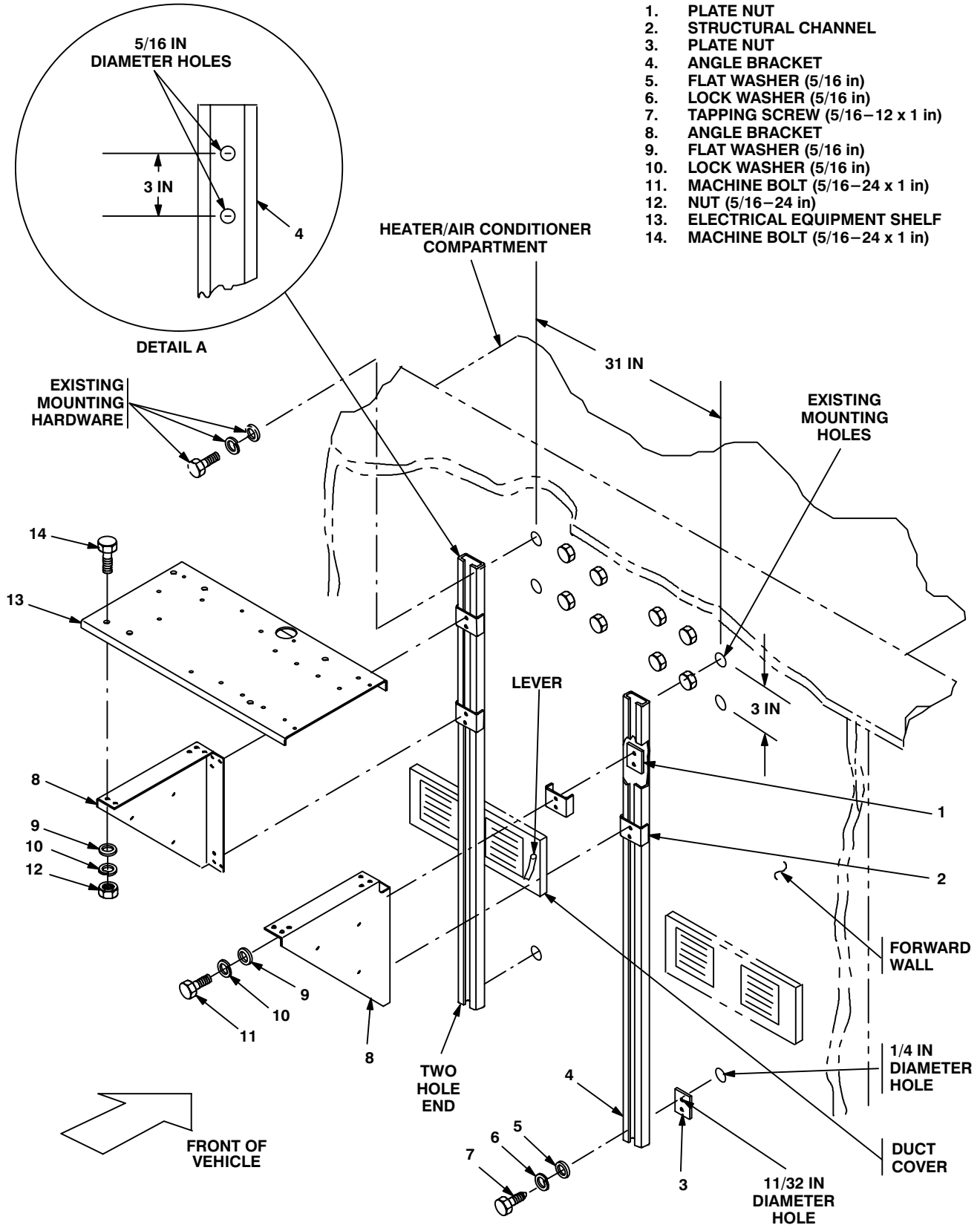

1. PLATE NUT
2. STRUCTURAL CHANNEL
3. PLATE NUT
4. ANGLE BRACKET
5. FLAT WASHER (5/16 in)
6. LOCK WASHER (5/16 in)
7. TAPPING SCREW (5/16-12 x 1 in)
8. ANGLE BRACKET
9. FLAT WASHER (5/16 in)
10. LOCK WASHER (5/16 in)
11. MACHINE BOLT (5/16-24 x 1 in)
12. NUT (5/16-24 in)
13. ELECTRICAL EQUIPMENT SHELF
14. MACHINE BOLT (5/16-24 x 1 in)

Figure 5-4 (1). Electrical Equipment Shelf Installation: Typical Installation

5.2 Installation of Electrical Equipment Shelf. Continued

ITEM	ACTION	REMARKS
k. Two holes in forward wall (below duct covers).	Using bottom hole in each angle bracket as a template, drill two 1/2 in diameter holes through inner panel of forward wall. See Figure 5–4(1). Remove a 1” diameter of paint around both sides of bottom holes in angle brackets (4). Clean the paint removed areas and apply a thin coat of conductive anti–seize compound.	Insure that angle brackets are vertical prior to drilling. Tools: Electric grinder or equivalent.
l. Two plate nuts (3).	Remove a 1” diameter of paint around both sides of hole that mate with bottom hole in angle bracket (4) and hole drilled in step k. Clean the paint removed areas and apply a thin coat of conductive anti–seize compound.	Tools: Electrical grinder or equivalent.
m. Two plate nuts (3), two hex–head tapping screws (7), two lock washers (6), and two flat washers (5).	Install (without securing) to two angle brackets (4) and holes drilled in step k.	Tools: 1/2 in socket.
n. Electrical equipment shelf (13) and two angle brackets (8).	Remove a 1” diameter of paint around both sides of forward mounting holes in electrical equipment shelf (13) and two angle brackets (8) that mate with each other; then clean the paint removed areas and apply a thin coat of conductive anti–seize compound.	Tools: Electric grinder or equivalent.
o. Four machine bolts (14), four flat washers (9), four lock washers (10), and four nuts (12).	Install (without securing) to electrical equipment shelf (13) and two angle brackets (8) See Figure 5–4(1).	Tools: 1/2 in socket and 1/2 in open/box wrench.
p. Mounting hardware.	Adjust height and leve of shelf; then secure.	Tools: 1/2 in socekt and 1/2 in open/box wrench.
q. Alternate installation A.	See figure 5–4 (2).	NOTE: Insure grinding and bonding procedures are performed during installation.
r. Alternate installation B.	See figure 5–4 (3).	NOTE: Insure grinding and bonding procedures are performed during installation.
s. Alternate installation C.	See figure 5–4 (4).	NOTE: Insure grinding and bonding procedures are performed during installation.
t. Alternate installation D.	See figure 5–4 (5).	NOTE: Insure grinding and bonding procedures are performed during installation.

5.2 Installation of Electrical Equipment Shelf. Continued

- 1. ANGLE BRACKET
- 2. PLATE NUT
- 3. STRUCTURAL CHANNEL
- 4. FLAT WASHER (5/16 in)
- 5. LOCK WASHER (5/16 in)
- 6. MACHINE BOLT (5/16-24 x 1 in)
- 7. NUT (5/16-24)
- 8. ANGLE BRACKET
- 9. ELECTRICAL EQUIPMENT SHELF
- 10. MACHINE SCREW (5/16-24 x 3/4 in)
(NOT SUPPLIED IN KIT)

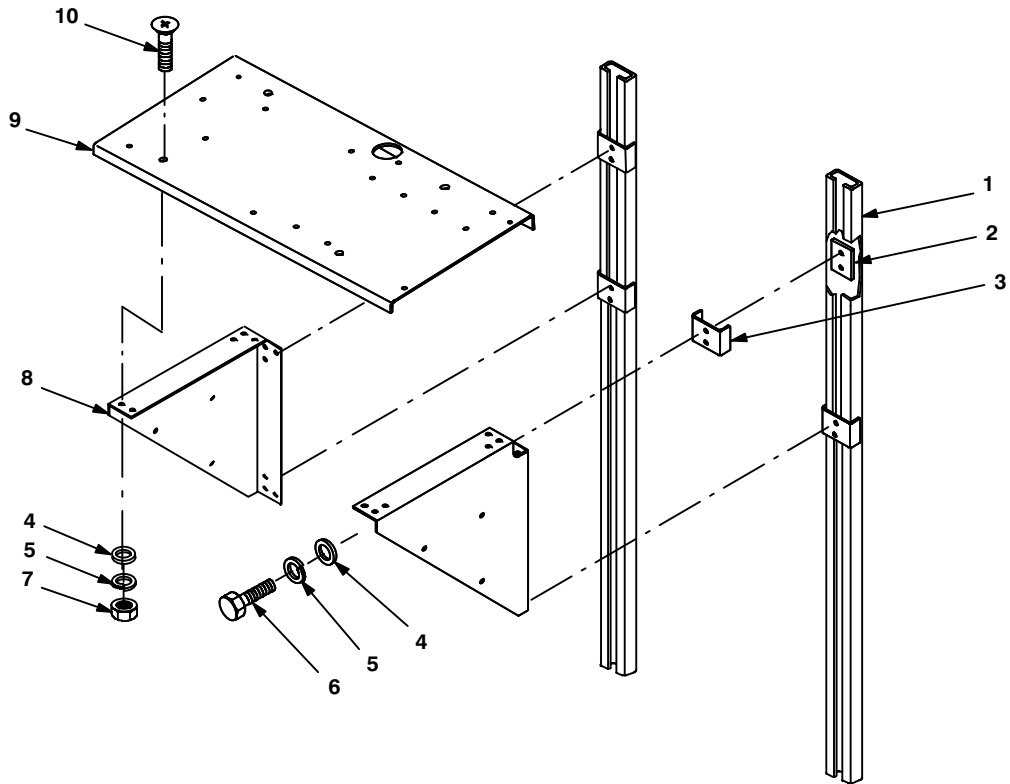
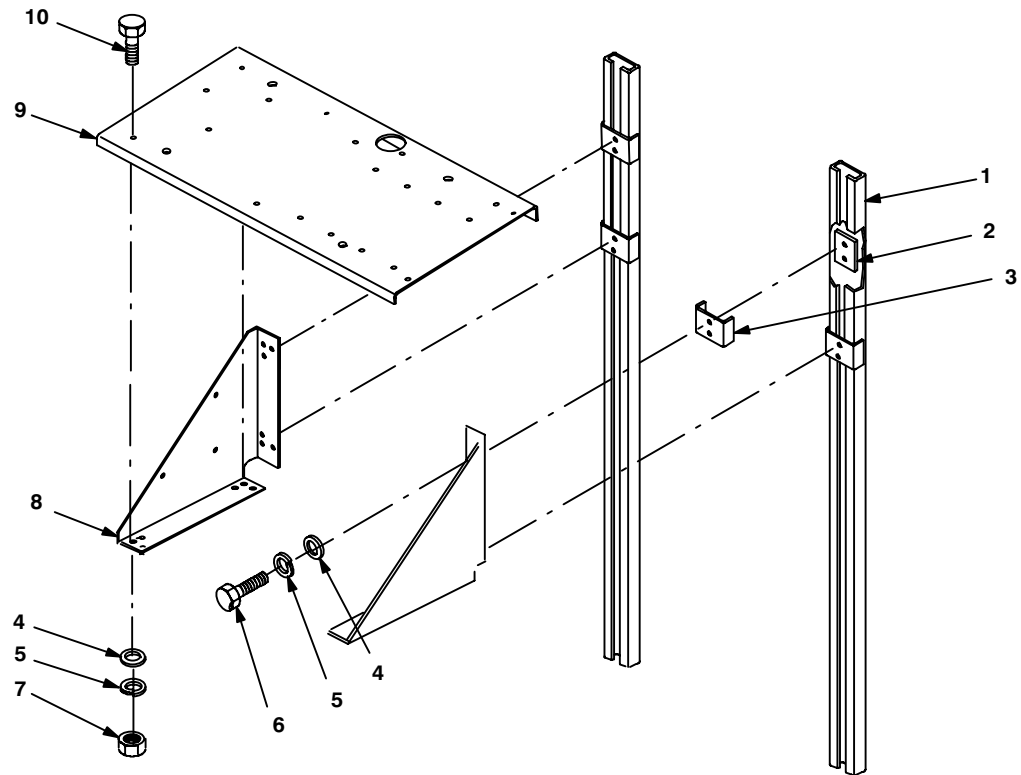

Figure 5-4 (2). Electrical Equipment Shelf Installation: Alternate Installation A

5.2 Installation of Electrical Equipment Shelf. Continued



- 1. ANGLE BRACKET
- 2. PLATE NUT
- 3. STRUCTURAL CHANNEL
- 4. FLAT WASHER (5/16 in)
- 5. LOCK WASHER (5/16 in)
- 6. MACHINE BOLT (5/16-24 x 1 in)
- 7. NUT (5/16-24 in)
- 8. ANGLE BRACKET
- 9. ELECTRICAL EQUIPMENT SHELF
- 10. MACHINE BOLT (5/16-24 x 1 in)

Figure 5-4 (3). Electrical Equipment Shelf Installation: Alternate Installation B

5.2 Installation of Electrical Equipment Shelf. Continued

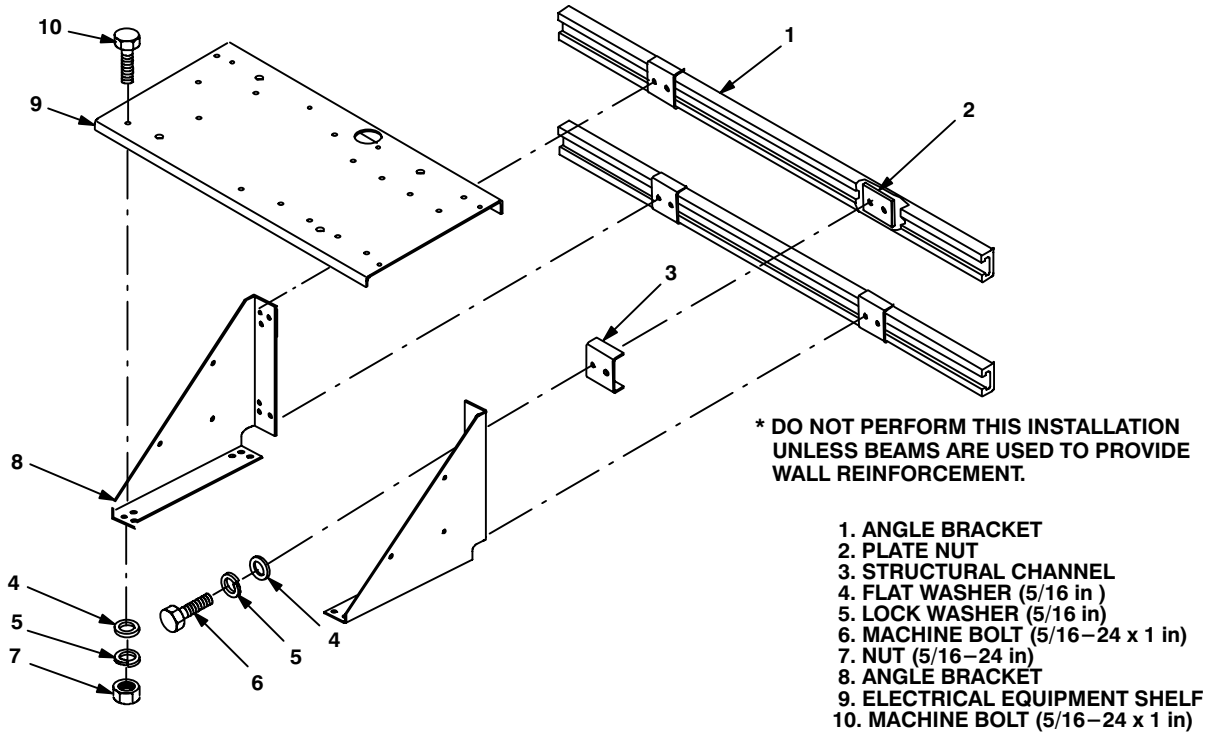

Figure 5-4 (4). Electrical Equipment Shelf Installation: Alternate Installation C

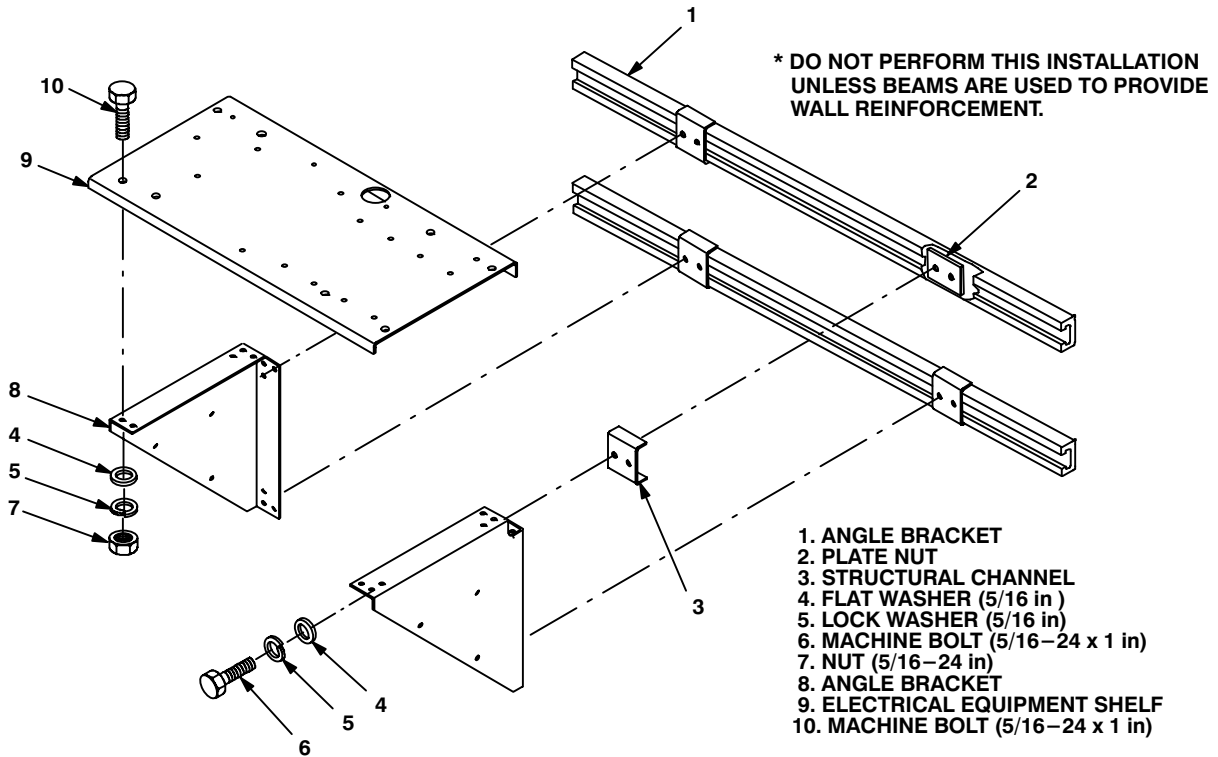

Figure 5-4 (5). Electrical Equipment Shelf Installation: Alternate Installation D

5.3 Installation of Loudspeaker – Control Unit LS-671/VRC (speaker). See figure 5-1 (1) for location.

ITEM	ACTION	REMARKS
a. Speaker (5).	Position top mounting hole under hole in electrical equipment shelf (4). See figure 5-5.	
b. Machine bolt (1), lock washer (2) and flat washers (3).	Install and secure to speaker (5) and electrical equipment shelf (4).	Tools: 1/2 in socket.
c. Handset (6).	Connect and secure to speaker (5) connector J2.	

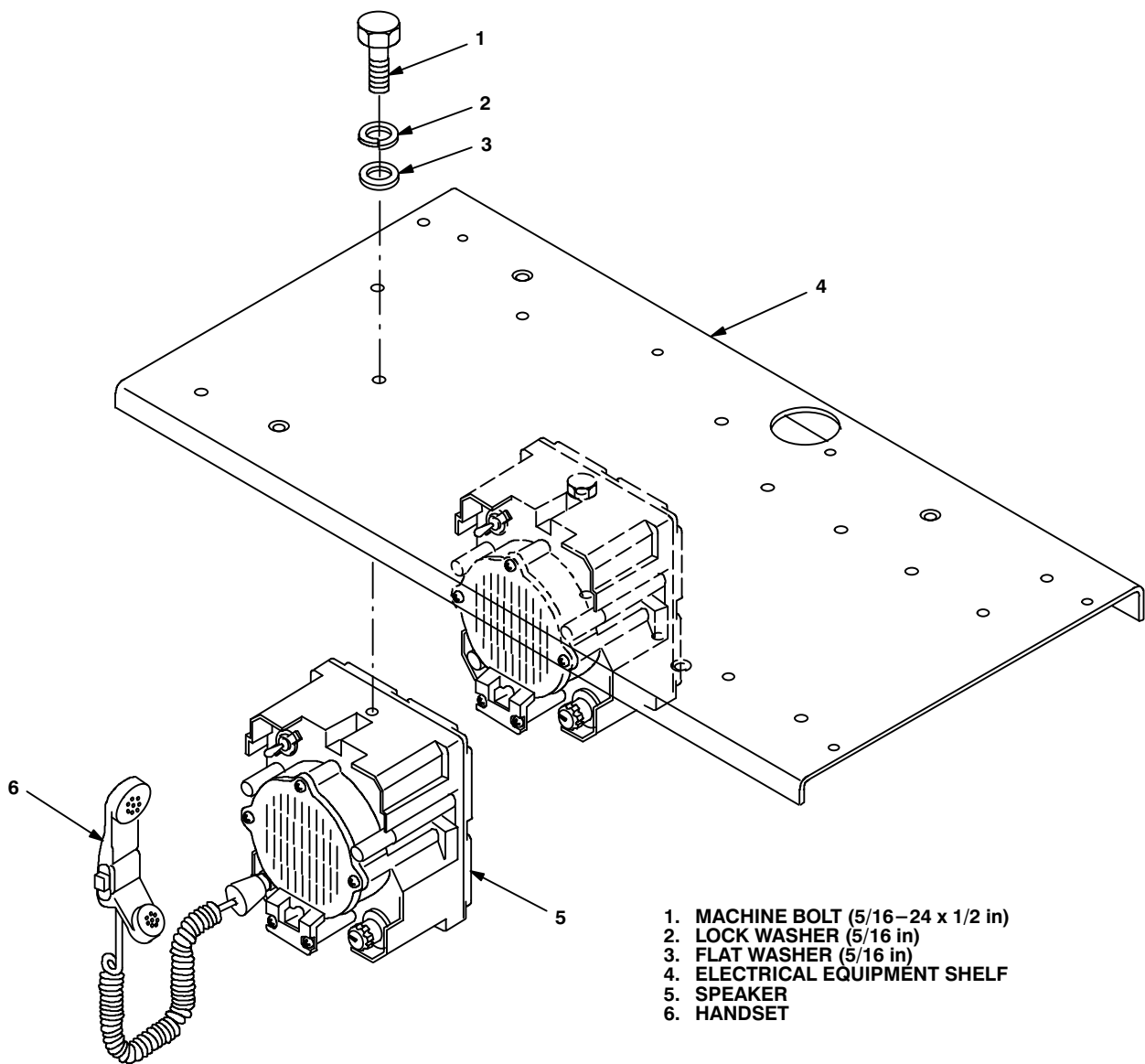

Figure 5-5. Speaker Installation: Electrical Equipment Shelf

5.4 Installation of Mounting Base, Electrical Equipment MT-6352/VRC (mounting base). Remove and retain attaching bag of 5/16 in mounting hardware for installation. To insure good electrical grounding, any rust, corrosion or paint around mounting holes in electrical equipment shelf should be removed before installing the mounting base. See figure 5-6 and perform the following steps.

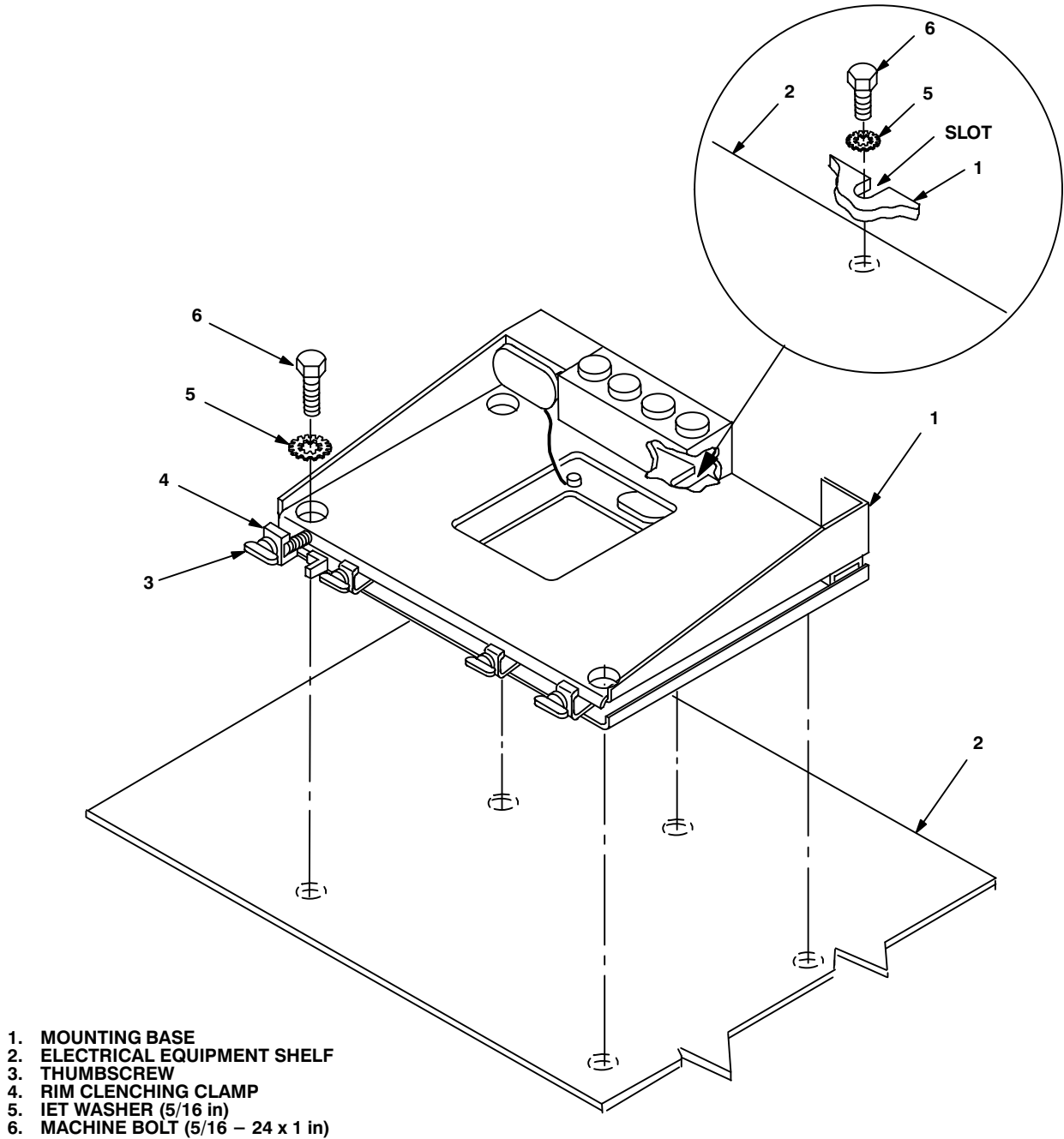

Figure 5-6. Mounting Base Installation

5.4 Installation of Mounting Base, Electrical Equipment MT-6352/VRC (mounting base). Continued

ITEM	ACTION	REMARKS
NOTE		
Apply a thin coat of adhesive-sealant to both sides of each internal/external-toothed (IET) washer during installation, and to the area of contact where IET washer is to be placed.		
a. Mounting base (1) and electrical equipment shelf (2).	Remove a 2" square area of paint on the underside of the mounting base (1) around left front and rear mounting holes. Remove a 2" square area of paint on the electrical equipment shelf around the existing mounting holes that mate with left front and rear mounting holes of mounting base (1). Clean the paint removed areas and apply a thin coat of conductive anti-seize compound.	Tools: Electric grinde or equivalent.
b. Mounting base (1).	Place on radio shelf over existing holes. See Figure 5-6.	
c. Two outer thumbscrews (3).	Turn ccw until both sets of threads have cleared center of holes. See Figure 5-6.	
d. Mounting base (1).	Align four holes and rear slot with matching hole pattern in shelf (2).	
e. Five machine bolts (6) and five IET washers (5).	Install and secure to mounting base (1) and shelf.	Tools: 1/2 in socket.
f. Two outer thumbscrews (3).	Tighten and secure to rim clenching clamps (4) and mounting base (1).	

5.5 Installation of Cables. To accomplish the installation, leave loop clamps and tiedown straps loose enough to adjust cable slack and allow easy adjustment of equipment. When installation is complete, tighten and secure clamps and tiedown straps.

WARNING

Make sure vehicle power source is positioned OFF or disconnected before installing cables.

ITEM	ACTION	REMARKS
a. Grommet (9).	Cut to 7 1/16 in length; then install to hole in electrical equipment shelf (10). See figure 5–7 (1).	
b. Speaker cable (11) connector P1.	Connect and secure to speaker (13) connector J1.	
c. Speaker cable (12) connector P1.	Connect and secure to speaker (14) connector J1.	
d. P2 connectors of speaker cables (11, 12).	Insert up through rear hole in electrical equipment shelf (10).	
e. Speaker cable (12) connector P2.	Connect and secure to mounting base (15) connector J3.	
f. Speaker cable (11) connector P2.	Connect and secure to mounting base (15) connector J4.	
g. P2 connectors of power cable (18) and RF cable (4).	Position on top of mounting base (15).	
h. RF cable (4) and power cable (18).	Route along rear edge of electrical equipment shelf (10) and forward wall to curbside area of heater/air conditioner compartment.	
i. Four loop clamps (8), four cap screws (1/4–20 x 3/4 in) and four lock washers (1/4 in).	Wrap clamps around RF cable (4) and power cable (18); then install to electrical equipment shelf (10). See figure 5–7 (1) for location(s).	Tools: 7/16 in socket.
j. Mounting hole for loop clamp (7).	Drill a 3/16 in diameter hole through inner panel of forward wall.	Tools: Electric drill and 3/16 in drill bit.
k. Loop clamp (7), pan-head tapping screw (1/4–14 x 3/4 in) and lock (1/4 in).	Wrap clamp around RF cable (4) and power cable (18); then install to hole drilled in step j.	Tools: Phillips screwdriver.
l. Loop clamp (6) and existing mounting hardware.	Wrap clamp around RF cable (4) and power cable (18); then install to forward wall.	

5.5 Installation of Cables. Continued

- | | |
|--|--|
| 1. ANTENNA BASE (ROADSIDE) | 12. SPEAKER CABLE, CX-13292/VRC (6 FT, 0 IN) |
| 2. ANTENNA BASE (CURBSIDE) | 13. SPEAKER (RIGHT) |
| 3. LOOP CLAMP (1/4-1/4 in) | 14. SPEAKER (LEFT) |
| TAPPING SCREW (1/4-14 x 3/4 in) | 15. MOUNTING BASE |
| LOCK WASHER (1/4 in) | 16. TIEDOWN STRAP |
| 4. RF CABLE, CG-3855/VRC (18 FT, 0 IN) | 17. RF CABLE, CG-3855/VRC (18 FT, 0 IN) |
| 5. LOOP CLAMP (5/8-1/4 in) | 18. POWER CABLE, CX-13302/VRC (20 FT, 0 IN) |
| TAPPING SCREW (1/4-14 x 3/4 in) | 19. LOOP CLAMP (1/4-1/4 in) |
| LOCK WASHER (1/4 in) | 20. GROMMET (1/4 in) |
| 6. LOOP CLAMP (3/4-1/4 in) | 21. RETAINER |
| 7. LOOP CLAMP (3/4-1/4 in) | 22. GROMMET (1/4 in) |
| TAPPING SCREW (1/4-14 x 3/4 in) | 23. TAPPING SCREW (1/4-14 x 1/2 in) |
| LOCK WASHER (1/4 in) | 24. LOCK WASHER (1/4 in) |
| 8. LOOP CLAMP (3/4-1/4 in) | |
| CAP SCREW (1/4-20 x 3/4 in) | |
| LOCK WASHER (1/4 in) | |
| 9. GROMMET | |
| 10. ELECTRICAL EQUIPMENT SHELF | |
| 11. SPEAKER CABLE, CX-13292/VRC (6 FT, 0 IN) | |

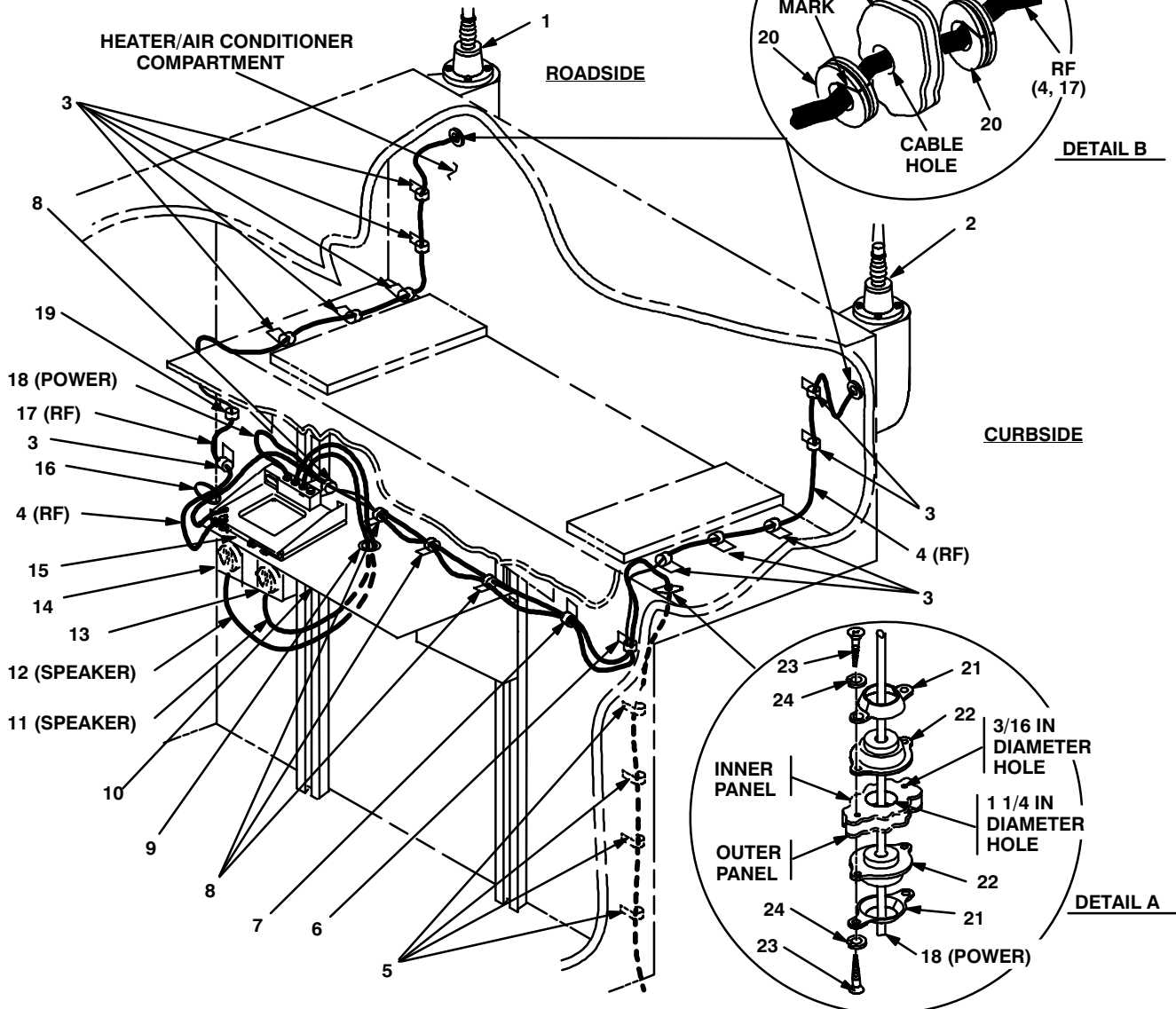

Figure 5-7 (1). Cable Installation: RF, Speaker and Power Cabling

5.5 Installation of Cables. Continued

ITEM	ACTION	REMARKS
m. Holes for grommet (22) and retainer (21).	Using retainer as a template, drill two 3/16 in diameter holes (through inner panel of heater/air conditioner compartment); then drill a 1 1/4 in diameter hole (through inner and outer panels). See figure 5–7 (1), detail A.	Tools: Electric drill, 3/16 in drill bit and 1 1/4 in drill bit.
n. Outer panel mounting holes for retainer (21).	Using retainer as a template, drill two 3/16 in diameter holes through outer panel of heater/air conditioner compartment.	Middle hole in retainer should be alined with 1 1/4 in diameter hole drilled in step m. Tools: Electric drill and 3/16 in drill bit.
o. Power cable (18).	Insert terminal leads (T1, T2) through 1 1/4 in diameter hole drilled in step m; then route cable down outer forward wall to cab floor.	
p. Two grommets (22).	Wrap around power cable (18); then insert in 1 1/4 hole (through inner and outer panels).	
q. Two retainers (21), four pan–head tapping screws (23) and four lock washers (24).	Install and secure to grommet (22) and 3/16 in diameter holes drilled in steps m and n.	Tools: Phillips screwdriver.
r. Curbside mounting holes for loop clamps (3).	Drill five 3/16 in diameter holes in heater/air conditioner compartment. See figure 5–7 (1) for curbside location(s).	Tools: Electric drill and 3/16 in drill bit.
s. Five loop clamps (3), five pan–head tapping screws (1/4–14 x 3/4 in) and five lock washers (1/4 in).	Wrap clamps around RF cable (4); then install to holes drilled in step r.	Tools: Phillips screwdriver.
t. RF cable (17) connector P2.	Position on top of mounting base (15). See figure 5–7 (1).	
u. RF cable (17).	Route up forward wall to heater/air conditioner compartment.	

5.5 Installation of Cables. Continued

ITEM	ACTION	REMARKS
v. Roadside mounting holes for loop clamps (3).	Drill six 3/16 in diameter holes; one in forward wall and five in heater/air conditioner compartment. See figure 5–7(1) for roadside location(s).	Tools: Electric drill and 3/16 in drill bit.
w. Six loop clamps (3), six pan-head tapping screws (1/4–14 x 3/4 in) and six lock washers (1/4 in).	Wrap clamp around RF cable (17); then install to holes drilled in step v.	Tools: Phillips screwdriver.
x. Loop clamp (19) and existing mounting hardware.	Wrap clamp around RF cable (17); then install to forward wall.	
y. RF cable (17) connector P1.	Insert through cable hole; then connect and secure to antenna base (1) connector J1. See figure 5–7 (1).	
z. RF cable (4) connector P1.	Insert through cable hole; then connect and secure to antenna base (2) connector J1.	
aa. Four grommets (20).	Cut through on mark shown; then wrap around RF cables (4,17) and insert in cable holes (in outer and inner panels of front wall). See figure 5–7 (1), detail B.	Thicker grommet installs to outer panel. Tools: Pocket knife.
ab. Mounting holes for loop clamps (5).	Drill four 3/16 in diameter holes through outer panel of forward wall. See figure 5–7 (1) for location(s).	Tools: Electric drill and 3/16 in drill bit.
ac. Four loop clamps (5), four pan-head tapping screws (1/4–14 x 3/4 in) and four lock washers (1/4 in).	Wrap clamp around power cable (18); then install to hole drilled in step ab.	Tools: Phillips screwdriver.
ad. Two loop clamps (4) and existing mounting hardware.	Wrap clamps around power cable (18); then install to existing holes. See figure 5–7 (2) for location(s).	
ae. Crew seat.	Raise and secure.	
af. Mounting hole for grommet (2).	Drill a 1 in diameter hole through cab floor. See figure 5–7 (2) for location(s).	Tools: Electric drill and 1 in drill bit.

5.5 Installation of Cables. Continued

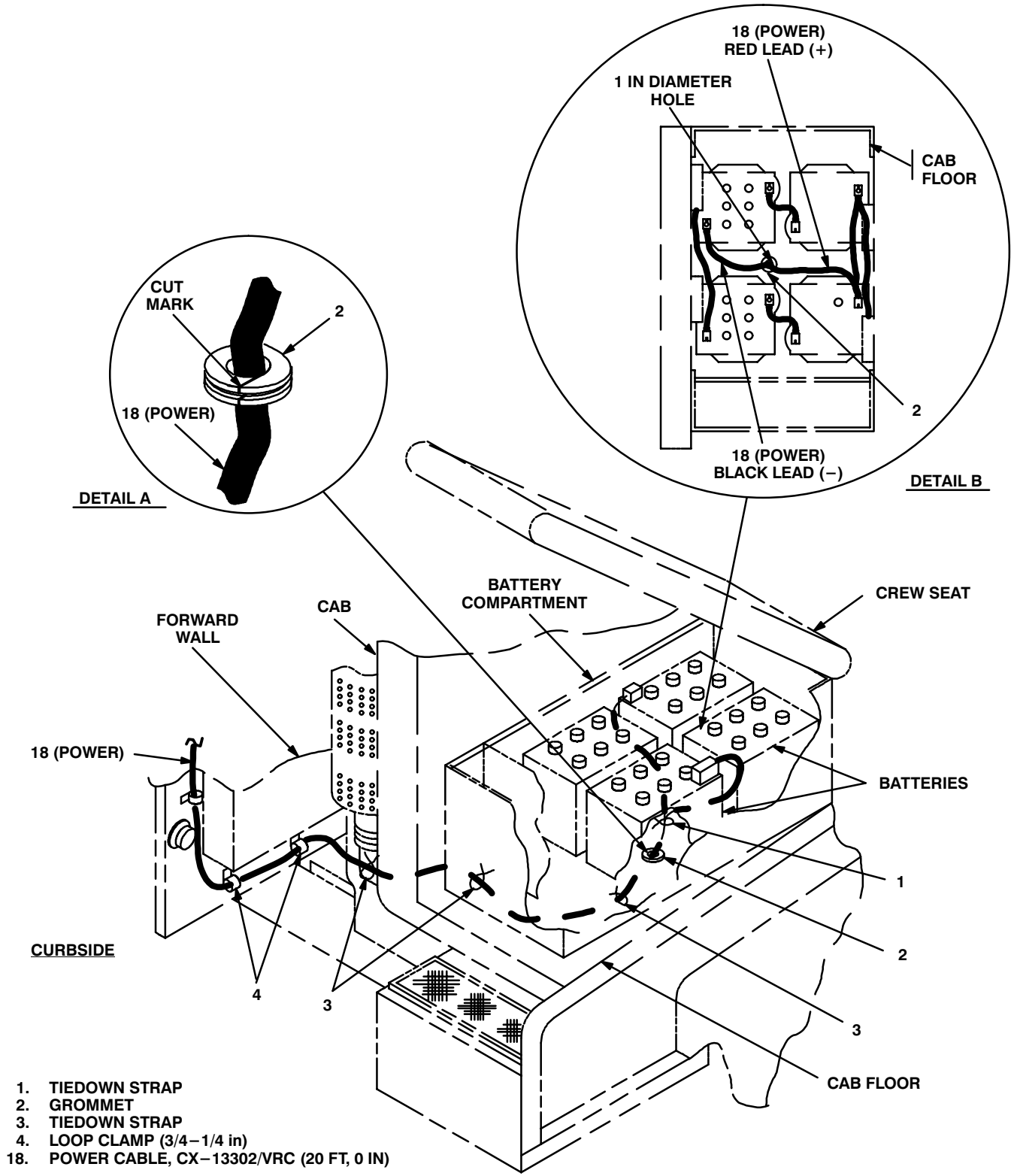

Figure 5-7 (2). Cable Installation: Power Cabling

5.5 Installation of Cables. Continued

ITEM	ACTION	REMARKS
ag. Power cable (18).	Route under cab floor to hole drilled in step af. See figure 5–7 (2).	
ah. Power cable (18) terminal leads: T1 (red) and T2 (black).	Insert through grommet hole (drilled in step af) into battery compartment.	
ai. Three tiedown straps (3).	Wrap around power cable (18); then loosely secure to existing cable wiring and plumbing. See figure 5–7 (2) for location(s).	
aj. Grommet (2).	Cut through on mark shown; then wrap around power cable (18) and install to hole drilled in step af. See figure 5–7 (2), detail A.	Tools: Pocket knife.
ak. Tiedown strap (1).	Wrap around power cable (18) red and black leads; then loosely secure to existing cable wiring.	
al. Power cable (18) terminal leads: T1 (red) and T2 (black).	Connect and secure to batteries. See figure 5–7 (2), detail B.	Red (+) secures to positive post. Black (–) secures to negative post.
am. Power cable (18) connector P2.	Connect and secure to mounting base (15) connector J1. See figure 5–7 (1).	
an. Adhesive–sealant.	Apply to all previously installed grommets and drilled holes.	
ao. Crew seat.	Lower and secure. See figure 5–7 (2).	

5.6 Installation of Mounting Base, Electrical Equipment MT-6353/VRC. If Radio Set AN/VRC-92 Series is authorized, use the following instructions to install MT-6353/VRC mounting base in the location shown in Figure 5-1 (2). Refer to section 5.7 for connection of cables.

ITEM	ACTION	REMARKS
------	--------	---------

NOTE

Apply a thin coat of adhesive-sealant to both sides of each internal/external-toothed (IET) washer during installation, and to the area of contact where IET washer is to be placed. Before proceeding, connect and secure CX-13291/VRC control cable and CX-13303/VRC power cable to MT-6353/VRC mounting base. (Refer to Section 5.7, step b.)

- | | | |
|--|--|--|
| a. MT-6353/VRC mounting base (1) and electrical equipment shelf (4). | Remove a 2" square area of paint on the underside of the mounting base (1) around the front two mounting holes. Remove a 2" square area of paint on the electrical equipment shelf (4) around the two front mounting holes. Clean the paint removed areas and apply a thin coat of conductive anti-seize compound. | Tools: Electric grinder or equivalent. |
|--|--|--|

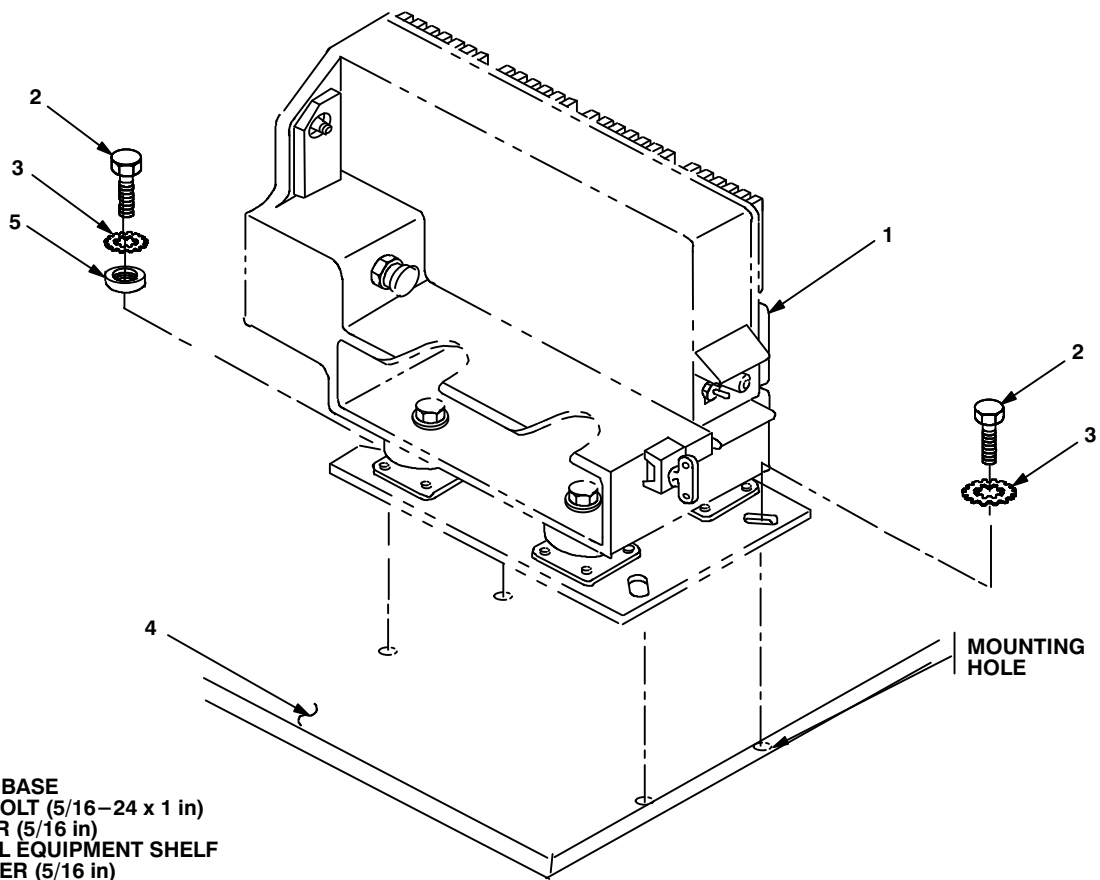

Figure 5-8. MT-6353/VRC Mounting Base Installation

5.6 Installation of Mounting Base, Electrical Equipment MT–6353/VRC. Continued

ITEM	ACTION	REMARKS
b. MT–6353/VRC mounting base (1).	Place on electrical equipment shelf (4) over existing holes. See Figure 5–8.	
c. MT–6353/VRC mounting base (1).	Align front holes and rear slots with matching hole pattern in shelf (4). See Figure 5–8.	
d. Two machine bolts (2), two IET washers (3) and two flat washers (5).	Install and secure to rear slots in MT–6353/VRC mounting base (1) and shelf (4).	Tools: 1/2 in open/box wrench.
e. Two machine bolts (2) and two IET washers (3).	Install and secure to front holes in MT–6353/VRC mounting base (1) and shelf (4).	Tools: 1/2 in socket or 1/2 in open/box wrench.

5.7 Post–Installation and Checkout. After equipment is installed and cables are connected, perform the following steps.

ITEM	ACTION	REMARKS
a. Equipment.	Check for secure mounting. Check for loose parts, connectors and mounting hardware.	
b. Cables.	Check for proper installation and connection of cables. See figure 5–9 for cable connections. Unused cables should be stowed in appropriate place inside the vehicle.	
c. Loop clamps.	Check that all have been properly installed and tightened.	
d. Protective covers.	Insure that all installed cables are covered when not in use or connected.	
e. Radio issued with vehicle.	Install and connect cables. See TM 11–5820–890–20–1 or TM 11–5820–890–20–2 for installation and Operational (OP) Check instructions.	
f. MK line replaceable units.	See TM 11–5820–890–20P for Repair Parts and Special Tools List (RPSTL) information.	

5.7 Post-Installation and Checkout. Continued

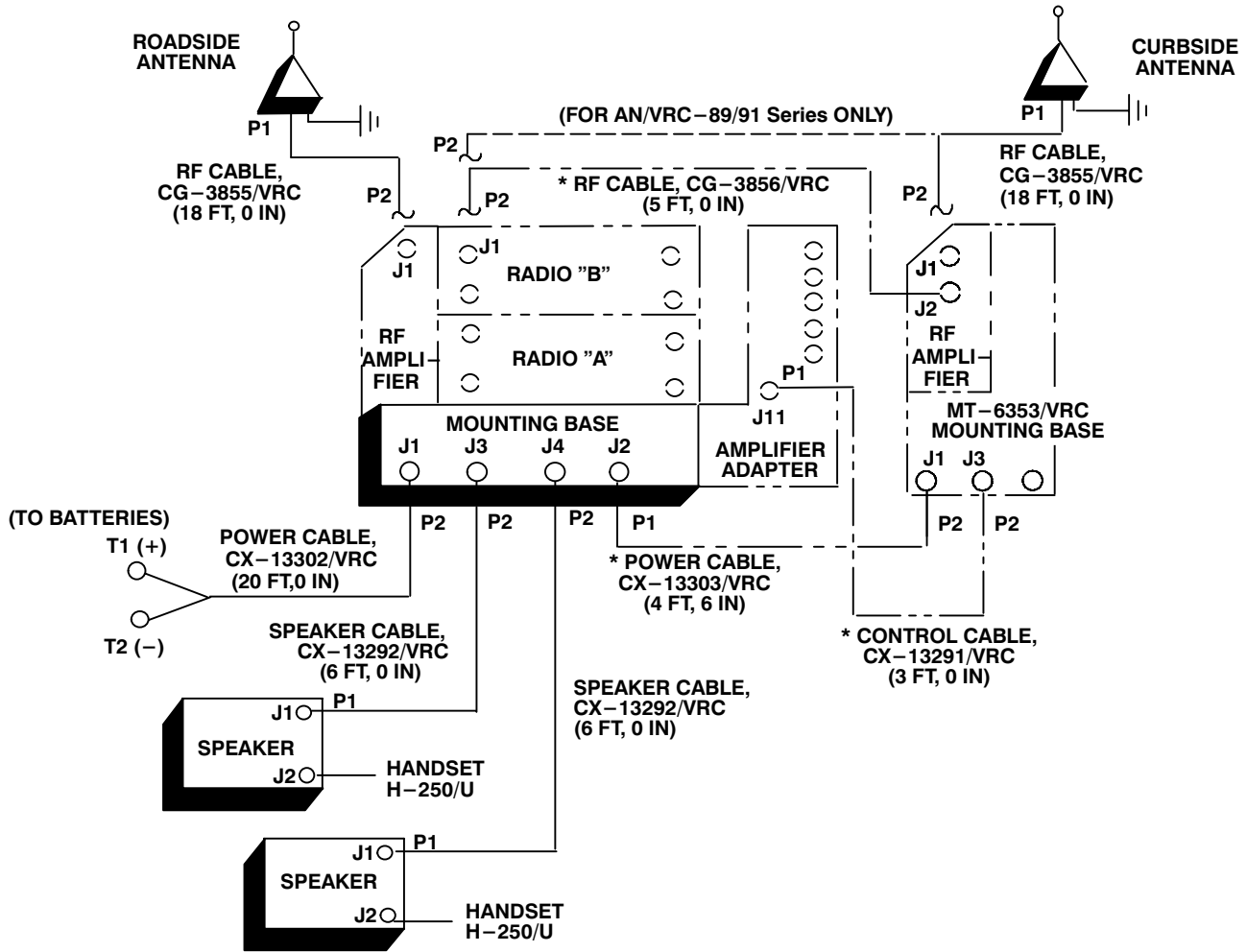

* NOT SUPPLIED IN THIS MK.

CABLE ASSEMBLY	FROM			TO		
	CABLE CONN.	UNIT	UNIT CONN.	CABLE CONN.	UNIT	UNIT CONN.
CX-13302/VRC (20 FT, 0 IN)	P2	Mounting base	J1	T1: Red (+) T2: Black (-)	Batteries	(+) lug (-) lug
CX-13292/VRC (6 FT, 0 IN)	P2	Mounting base	J3	P1	Speaker (left)	J1
CX-13292/VRC (6 FT, 0 IN)	P2	Mounting base	J4	P1	Speaker (right)	J1
CG-3855/VRC (18 FT, 0 IN)	P2	RF amplifier	J1	P1	Roadside antenna base	J1

Figure 5-9. Cable Diagram: For AN/VRC-89/91/92 Series

5.7 Post-Installation and Checkout. Continued

CABLE ASSEMBLY	FROM			TO		
	CABLE CONN.	UNIT	UNIT CONN.	CABLE CONN.	UNIT	UNIT CONN.
CG-3855/VRC (18 FT, 0 IN)	P2	Radio "B" or RF amplifier (MT-6353/VRC)	J1	P1	Curbside antenna base	J1
* CX-13291/VRC (3 FT, 0 IN)	P1	Amplifier-adapter	J11	P2	MT-6353/VRC mounting base	J3
* CG-3856/VRC (5 FT, 0 IN)	P2	Radio "B"	J1	P1	RF amplifier (MT-6353/VRC)	J2
* CX-13303/VRC (4 FT, 6 IN)	P1	Mounting base	J2	P2	MT-6353/VRC mounting base	J1

* Not supplied in this MK.

Figure 5-9. Cable Diagram: For AN/VRC-89/91/92 Series Continued

APPENDIX A

REFERENCES

AMDF	Army Master Data File (Microfiche)
AR 710-2	Supply Policy Below the Wholesale Level as Contained in Unit Supply UPDATE
AR 725-50	Requisitioning, Receipt and Issuing System in UPDATE
DA Pam 25-30	Consolidated Index of Army Publications (Microfiche)
DA Pam 710-2-1	Using Unit Supply System Manual Procedures as Contained in Unit Supply UPDATE
SB 11-131	Vehicular Radio Sets and Authorized Installations (SINCGARS)
TM 11-5820-890-10-1	Operator's Manual (ICOM Radio Sets)
TM 11-5820-890-10-3	Operator's Manual (Non-ICOM Radio Sets)
TM 11-5820-890-20-1	Unit Maintenance Manual (ICOM Radio Sets)
TM 11-5820-890-20-2	Unit Maintenance Manual (Non-ICOM Radio Sets)
TM 11-5820-890-20P	Repair Parts and Special Tools List

By Order of the Secretary of the Army:

Official:

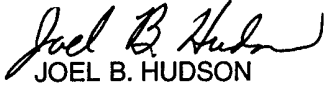

JOEL B. HUDSON
*Administrative Assistant to the
Secretary of the Army*

9923604

ERIC K. SHINSEKI
*General, United States Army
Chief of Staff*

DISTRIBUTION:

To be distributed in accordance with the initial distribution number (IDN) 369538 requirements for TB 11-5820-890-20-33.

SOMETHING WRONG WITH THIS PUBLICATION



THEN ... JOT DOWN THE INFO ABOUT IT ON THIS FORM. CAREFULLY TEAR IT OUT. FOLD IT AND DROP IT IN THE MAIL.

FROM: (PRINT YOUR UNIT'S COMPLETE ADDRESS)

Commander
Stateside Army Depot
ATTN: AMSTA-US
Stateside, NJ 07703-5007

DATE SENT

10 July 1995

PUBLICATION NUMBER

TM 11-5840-340-12

PUBLICATION DATE

23 Jan 74

PUBLICATION TITLE

Radar Set AN/PRC-76

BE EXACT PIN-POINT WHERE IT IS

IN THIS SPACE TELL WHAT IS WRONG AND WHAT SHOULD BE DONE ABOUT IT:

PAGE NO	PARA-GRAPH	FIGURE NO	TABLE NO
2-25	2-28		
3-10	3-3		3-1
5-6	5-8		
		FO-3	

Recommend that the installation antenna alignment procedure be changed throughout to specify a 20 IFF antenna lag rather than 10

REASON: Experience has shown that with only a 10 lag, the antenna servo system is too sensitive to gusting in excess of 25 knots, and has a tendency to rapidly accelerate and decelerate as it hunts, causing strain to the drive train. Hunting is minimized by adjusting the lag to 20 without degradation of operation.

Item 5, Functional column. Change 2 dB" to 3 dB".

REASON: The adjustment procedure for the TRANS POWER FAULT indicator call for a 3 dB (500 watts) adjustment to light the TRANS POWER FAULT indicator.

Add new step f.1 to read, Replace cover plate removed in step d above."

REASON: To replace the cover plate.

ZONE C 3. On J1-2, change +24 VDC" to +5 VDC".

REASON: This is the output line of the 5 VDC power supply. +24 VDC is the input voltage.

PRINTED NAME, GRADE OR TITLE AND TELEPHONE NUMBER

SSG I. M. DeSpirito 999-1779

SIGN HERE

TEAR ALONG DOTTED LINE

SOMETHING WRONG WITH THIS PUBLICATION



THEN ... JOT DOWN THE INFO ABOUT IT ON THIS FORM. CAREFULLY TEAR IT OUT. FOLD IT AND DROP IT IN THE MAIL.

--

DATE SENT

PUBLICATION NUMBER

PUBLICATION DATE

PUBLICATION TITLE

BE EXACT PIN-POINT WHERE IT IS

IN THIS SPACE TELL WHAT IS WRONG AND WHAT SHOULD BE DONE ABOUT IT:

PAGE NO	PARA-GRAPH	FIGURE NO	TABLE NO

--

TEAR ALONG DOTTED LINE

PRINTED NAME, GRADE OR TITLE AND TELEPHONE NUMBER

SIGN HERE

FILL IN YOUR
UNIT'S ADDRESS

FOLD BACK

DEPARTMENT OF THE ARMY



OFFICIAL BUSINESS

PLEASE
AFFIX
STAMP
POSTAGE
REQUIRED

TEAR ALONG DOTTED LINE

Commander
U.S. Army Communications-Electronics Command
and Fort Monmouth
ATTN: AMSEL-LC-LEO-D-CS-CFO
Fort Monmouth, New Jersey 07703-5000



FOLD BACK

